



Specification of the Stray Field Issue and the MICE Hall Model

P J Smith

23rd September 2013



Overview



Introduction: The MICE Magnets and Defining the Problem.

Specification

MICE Hall Model

Vector Field Reports on the Model

Tour of the Model

Comments

Shield Wall Model

Substation Model

How much does the picture change at Step VI?

Conclusions



The MICE Magnets



The MICE superconducting magnets were designed without return yokes (circa 2000 to ~2004). About two years ago Mike Courthold and Vicky Bayliss (RAL) started to build and run some simulations of the cooling channel that indicated that there may be a problem with the stray fields produced by the MICE magnets; the predicted air fields from the MICE magnets were of sufficient magnitude to be of concern.

There was clear indication that there was the possibility of some risk to the reliable functioning of equipment primarily within and possibly beyond the MICE hall.

What are the reasons for these magnet not having return yokes?...some speculation as no-one is really holding their hand up and they were designed before I was involved.

At this stage the reason is irrelevant. It's a problem that we have and it's a problem that we urgently need to solve!



Step IV: Compressors

5

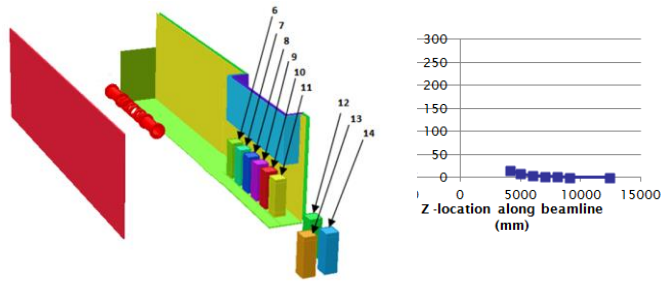

Step VI: Compressors

4

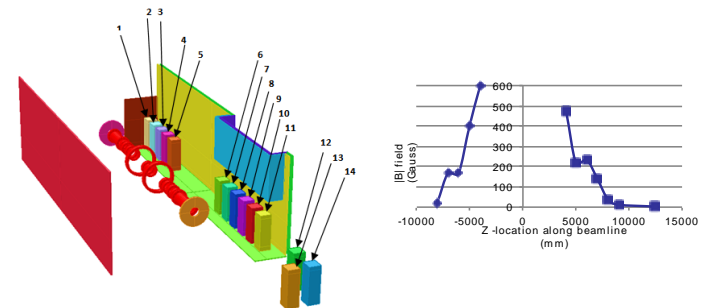

Step IV: Magnet Control Racks

6

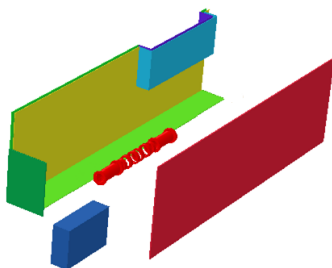

Simplified solution shows it is possible to shield in 5mm US1010 iron and 5mm mu-metal if Aluminium racks are used.

In reality, we will need to provide protected access (labyrinth or air-lock style) to allow access during magnet operation.

This implies serious modifications to the positions of magnet control racks, their services and the entrance to the trench.



Step IV: Electrical Racks on North Mezzanine

7

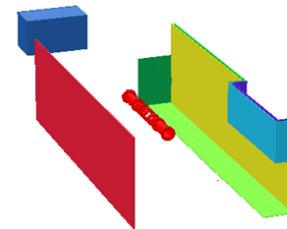

- 4 racks located on the north mezzanine
- 5mm US1010 iron and 5mm mu-metal if Aluminium racks are used.
- Estimated weight 3-5 tonnes – requires major modifications to the north mezzanine

Defining the Problem

Since then a significant amount of work done has to been to try and ascertain:

- What is the extent of the problem?
- What areas of the experimental hall are particularly affected?
- What items are particularly affected?

- Are there areas of the experimental hall that are not so badly affected by stray field and is it ok to put equipment in those areas?

- Where equipment can't be moved, what is the effect of the field on that equipment and if necessary can it be mitigated?

- **Can the field be mitigated with a retrofitted return yoke?**

- In trying to fix this problem what specification do we need to work to?



Specification



- 1) We need to find a solution that permits the MICE magnets to be utilised to their full operating currents, in both flip and solenoid mode for Step IV of the experiment.
- 2) The solution must be practical, insomuch that it must not place unreasonable constraints upon the ability to operate the experiment both in terms of physical access to the various components of the experiment and the amount of time it takes to run the experiment.
- 3) All equipment belonging to MICE and ISIS must function normally. Not only does this include equipment that is specific to the experiment itself but also covers the infrastructure that supports the experiment and the surrounding buildings.
- 4) All health and safety requirements with respect to personnel safety in magnetic fields must be adhered to.



MICE Hall Model



In order to further understand the issues with the stray field of the MICE magnets it was deemed prudent to build a magnetic model of the MICE Hall to give us further insight into the likely effect of the stray field throughout and beyond the volume of the MICE Hall. This model should be capable of:

- 1) Producing field maps for a variety of magnet configurations that would permit a better understanding of potential issues arising within the hall from not having a return yoke on the cooling channel magnets. This in turn would guide the necessary mitigation work for the baseline design.
- 2) To allow members of the collaboration to have access to estimates of the likely field levels in the vicinity of their equipment.



MICE Hall Model



The MICE hall represents a significant volume of approximately 40m x 12m x 12m and contains a significant amount of ferrous material. There is no symmetry to exploit. There is also much interest in how the fields penetrate beyond the confines of the MICE hall, particularly on the South Side. The total volume of the model has turned out to be approximately 120m x 80m x 80 m.

Building an FEA model on this scale requires a careful balance between detail and mesh size. This means that certain ferrous objects have not been modelled and in some cases some detail in the objects has been omitted to make the problem tractable.

The models contains:

- The bulk ferrous components contained within the MICE hall
- Many reference structures that are not magnetic.

The model does not contain:

- Ferrous components that were going to be difficult to mesh (in some cases where the mass the significant approximations have been used.)
- Racks, instrumentation, other fine detailed structures.

MICE Hall Model

The MICE Hall model with the relative compass directions – these are used frequently to reference structures. The buildings on the south side of the Hall model have been omitted as have a few of the structures on the North side to aid viewing.

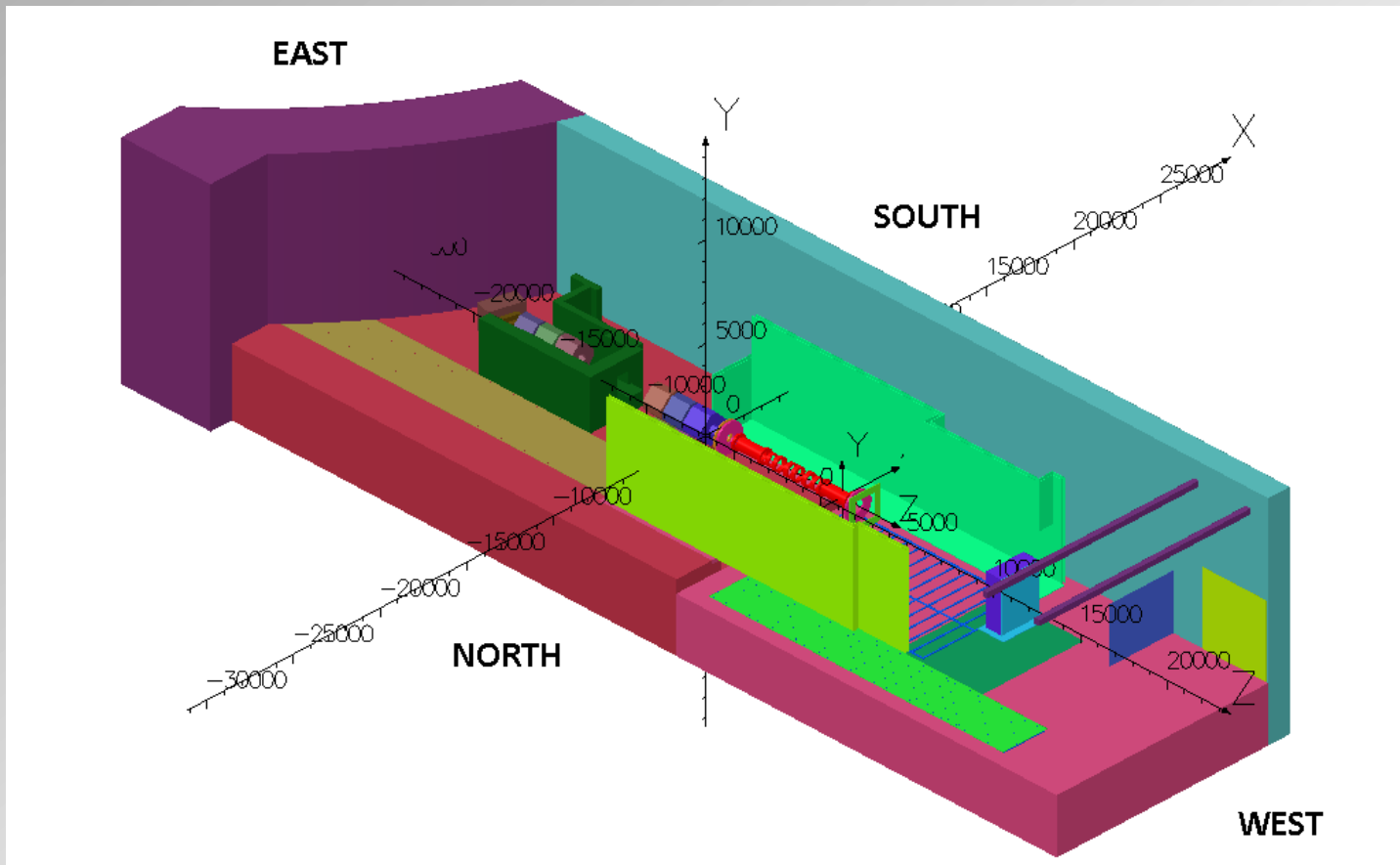

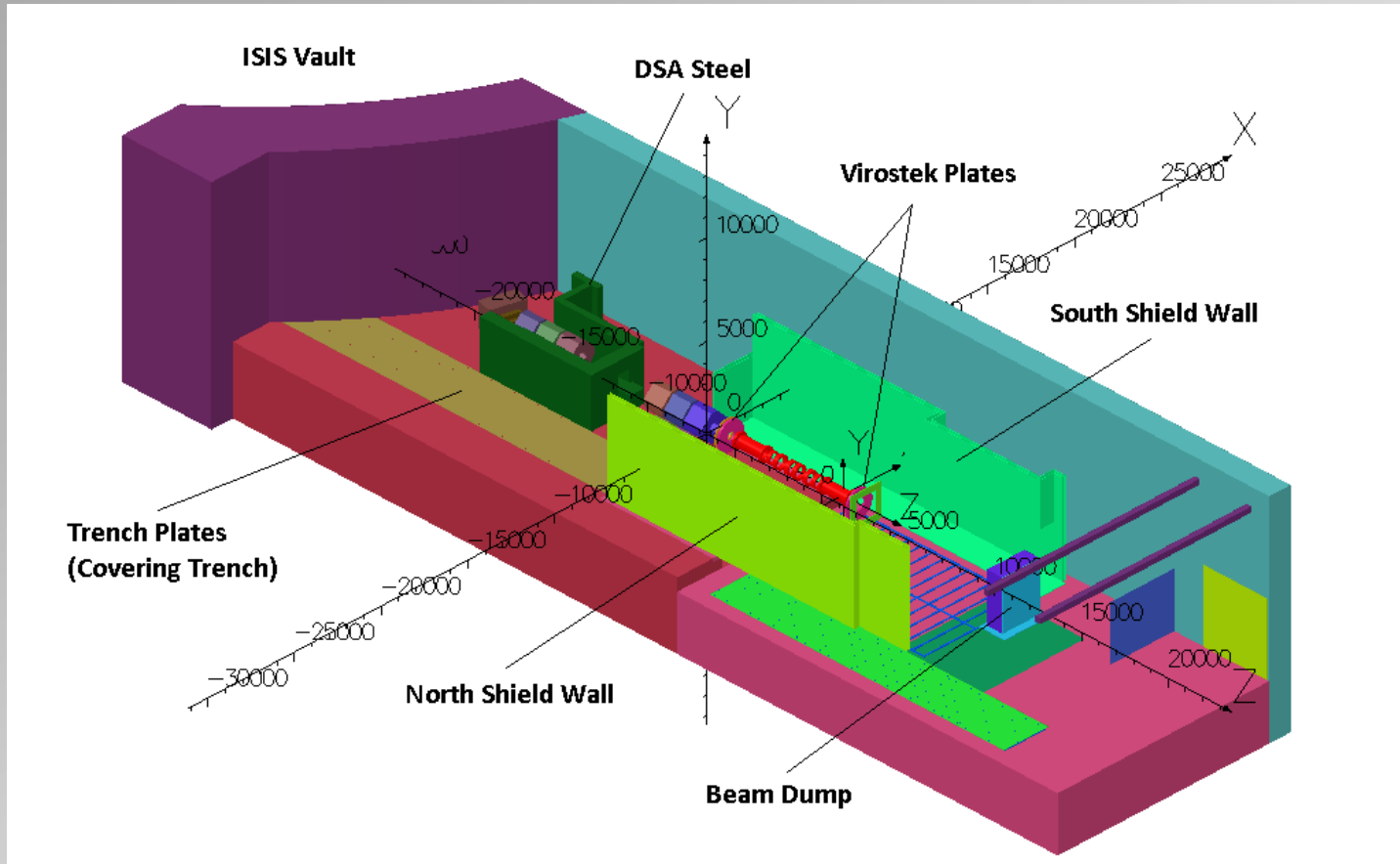

A few of the items are labelled for reference. A complete description of the components included in the model are described in the report. Most of the results presented are taken from hall models 91-96. These models represent the latest iteration of the Hall models and are available online.



VF Reports



We approached Vector Fields and asked them to validate the Hall model. We also asked for some advice on specific issues relating to using the hall model as a basis for sub-modelling.

These reports have now been published and are available on the modelling website at:

http://www.hep.shef.ac.uk/research/mice/opera_models/

Vector field produced two reports, the first deals with the hall model itself whilst the second deals with issues surrounding sub-modelling and how that would integrate with the hall model.

A lot of conclusions were drawn in these reports, and these have been discussed in detail in the review documentation – I don't have time to cover all of what was discussed in this presentation but I will briefly look at one or two areas they looked at from the first report.



VF Reports



Comparison of fields in free space

By comparing of a couple of line integrals and a patch on a model with all the elements set to air with Biot Savart Calculations it was determined that the error on those compared areas was less than or equal to 0.21%. This is indicative of the error introduced by the finite mesh.

Adding ferromagnetic components to the model

It is probable that the MICE Hall model already contains enough of the significant components for the fields in free space to be accurate within 1 or 2% - remembering of course that all fields may be at least 0.2 % of the all 'free space' value in error anyway. From Cobham's knowledge of the MICE Experimental Hall, there do not appear to be any major components that have been omitted that will further significantly affect results'



VF Reports



Investigation of material property variations

In this item the magnetisation values of BH curves of the steel was reduced by 10% and the effect on the three patches within the hall volume was calculated. The observed changes were usually well below 5%. The reduction in the magnetisation of the shielding walls means that they are not performing quite as well but as they are generally far from saturation in model 91 the effect is quite small.

Investigation of mesh quality

The hall model has been run using quadratic elements throughout as this is the safest and most accurate method of calculating the fields....To investigate whether the use of quadratic elements was necessary two models were run, one with mixed elements and one with all linear elements. The integrated fields on the patches were compared with the results from the quadratic model.

The results showed that on the patches examined the benefit of using quadratic elements was marginal yet the solve time improvement was significant.

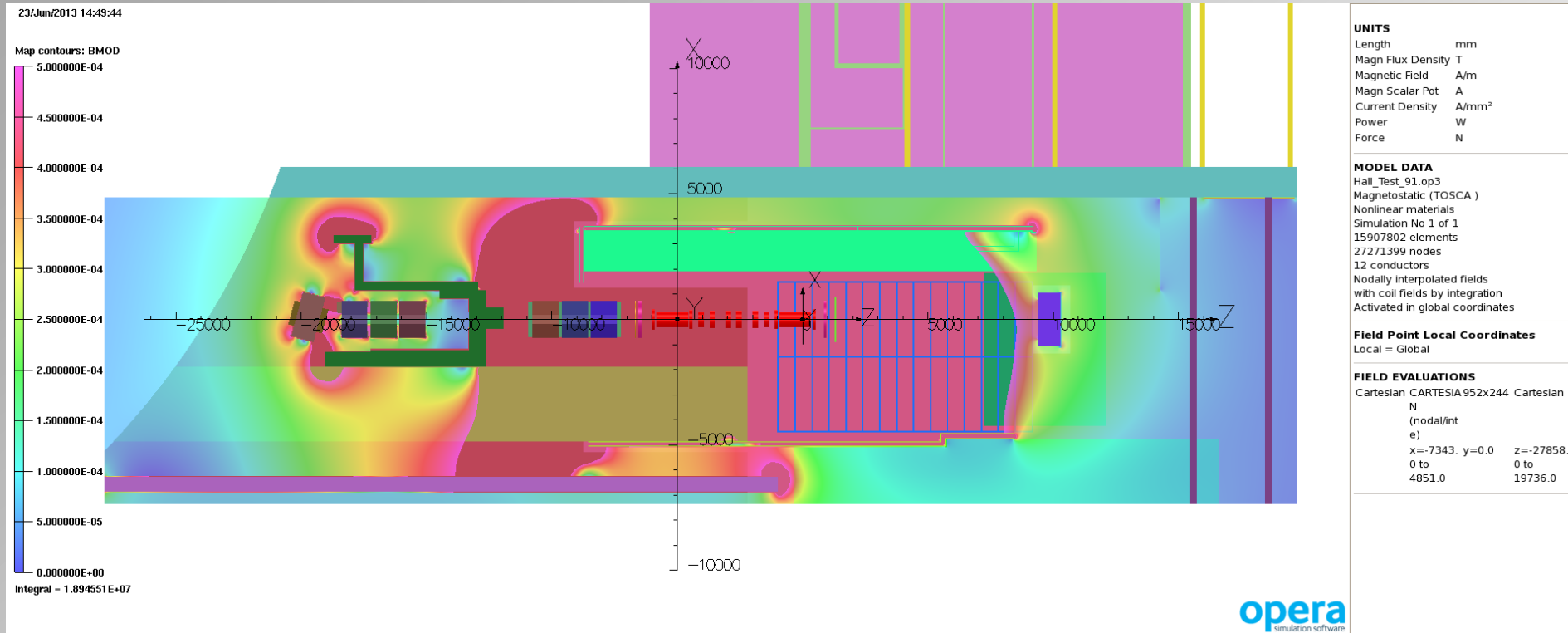

Model 91 – Step IV Solenoid 240 MeV/c – $y=0$ (beam height) - 5 gauss scale. This gives some indication of where the 5 gauss boundary lies in this model.

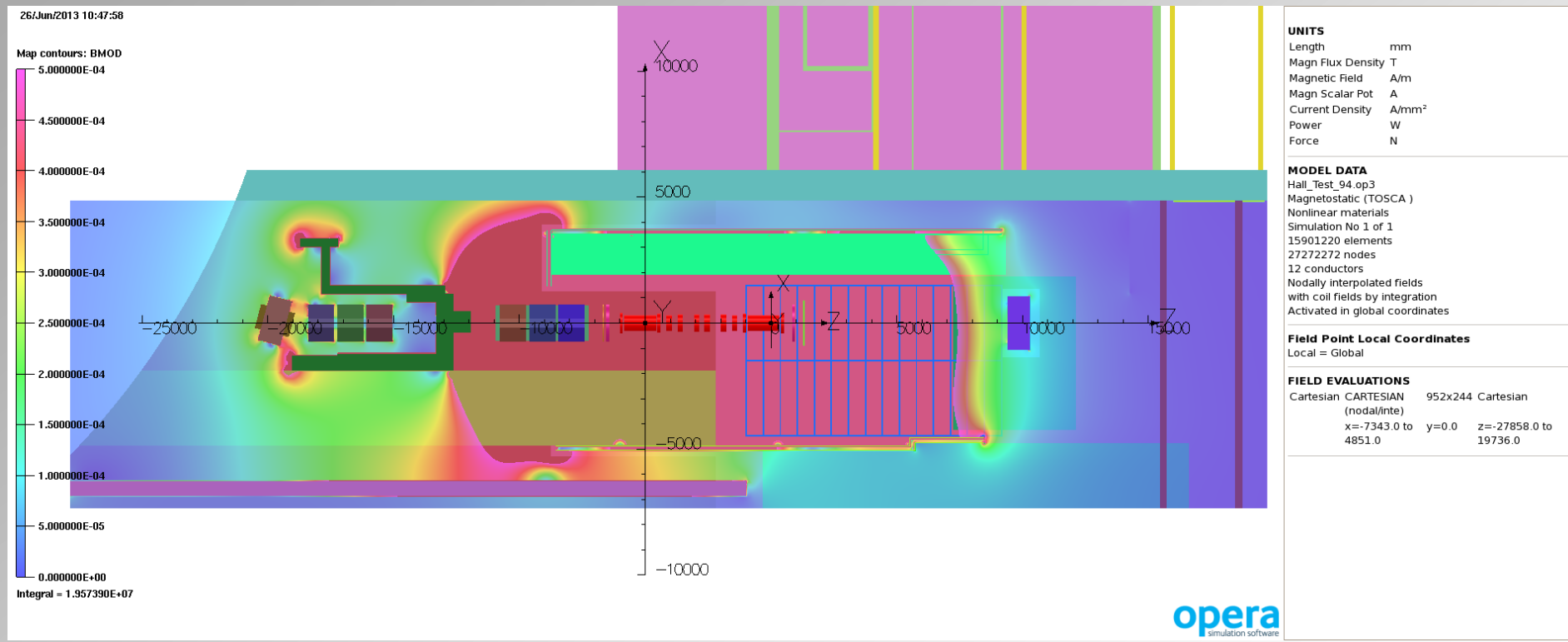

Model 91 – Step IV **Flip** mode 240 MeV/c – $y=0$ (beam height) - 5 gauss scale.
This gives some indication of where the 5 gauss boundary lies in this model.

By flipping between this and the previous slide it is clear that solenoid mode produces more fringe field.

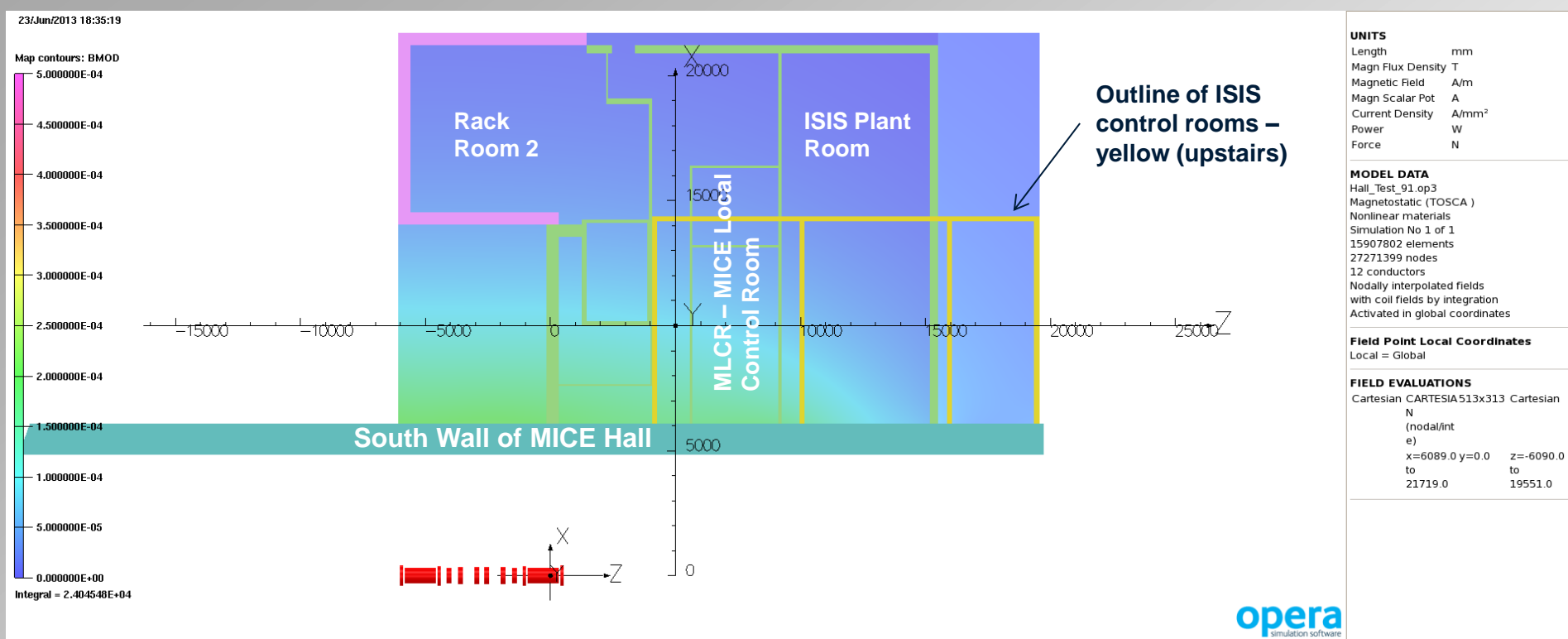

Model 91 – Step IV Solenoid 240 MeV/c – $y=0$ (beam height) - 5 gauss scale. One can immediately see that the field through this volume doesn't look to worrying but we'll take a closer look at some specific volumes shortly.

20 Jul 2013 18:11:07

Map contours: BMOD

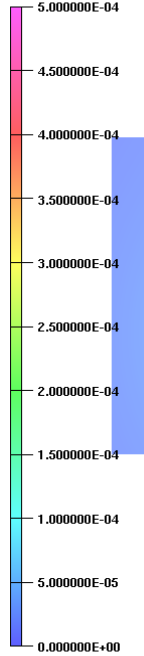

Integral = 6.419523E+04

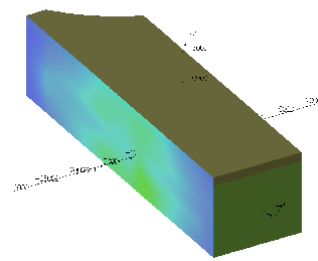
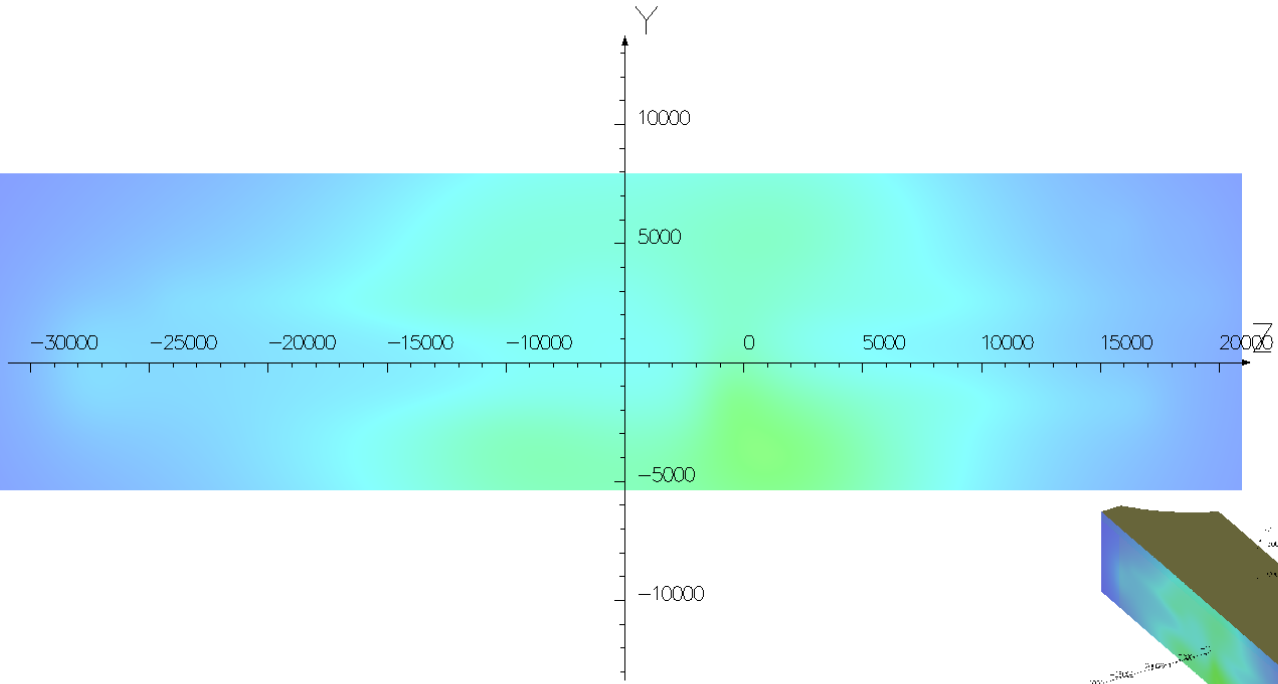

UNITS

Length	mm
Magn Flux Density	T
Magnetic Field	A/m
Magn Scalar Pot	A
Current Density	A/mm ²
Power	W
Force	N

MODEL DATA
 Hall_Test_91.op3
 Magnetostatic (TOSCA)
 Nonlinear materials
 Simulation No 1 of 1
 15907802 elements
 27271399 nodes
 12 conductors
 Nodally interpolated fields
 with coil fields by integration
 Activated in global coordinates

Field Point Local Coordinates
 Local = Global

FIELD EVALUATIONS

Cartesian	CARTESIAN	267x1079	Cartesian
(nodal/inte)			
x=-8567.0	y=-5375.0 to	z=-33005.0 to	
	7953.0	20960.0	

Model 91 – Step IV Solenoid 240 MeV/c – 5 gauss scale
 North Wall (external)

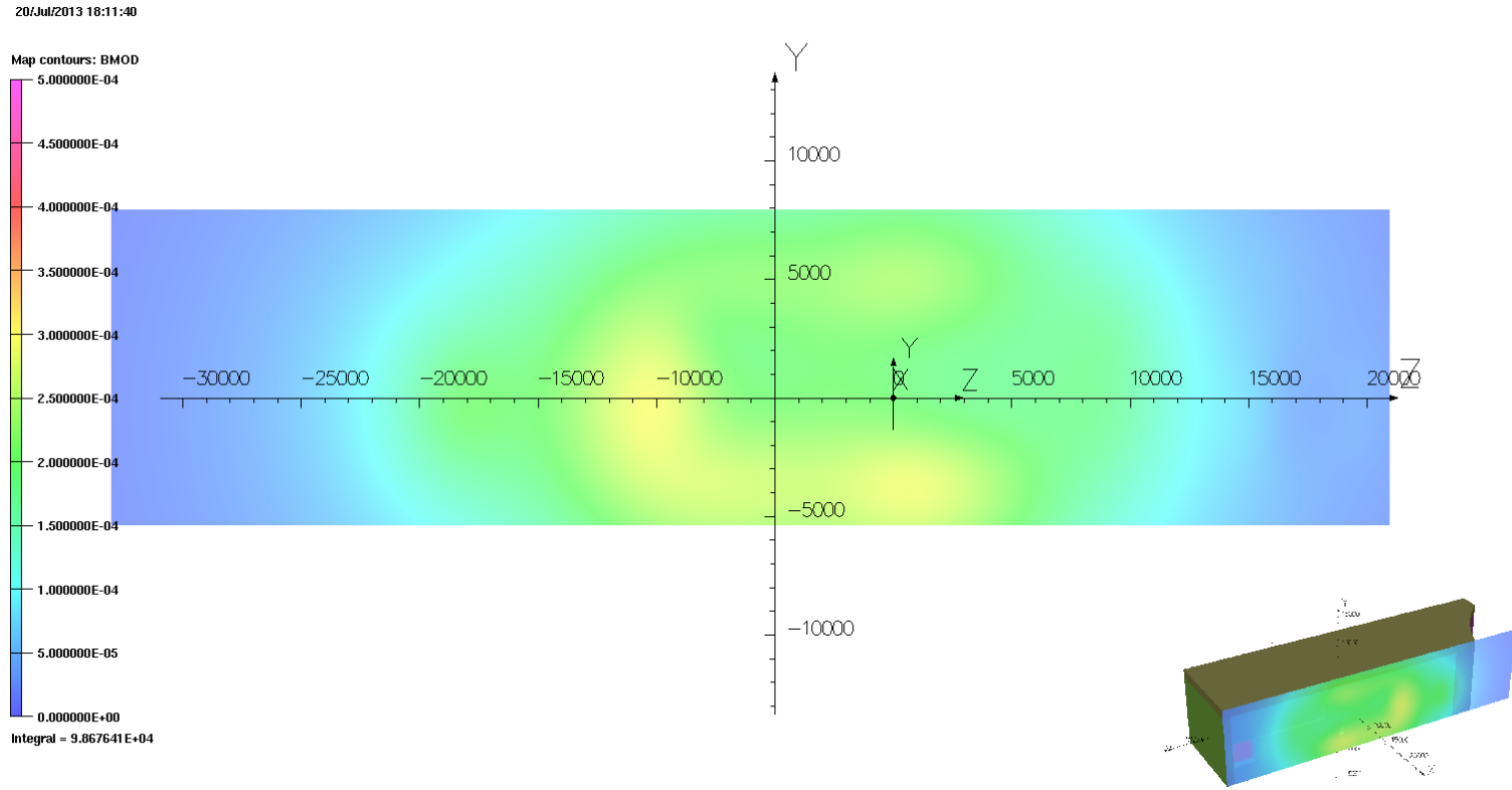

UNITS

Length	mm
Magn Flux Density	T
Magnetic Field	A/m
Magn Scalar Pot	A
Current Density	A/mm ²
Power	W
Force	N

MODEL DATA

Hall_Test_91.op3
 Magnetostatic (TOSCA)
 Nonlinear materials
 Simulation No 1 of 1
 15907802 elements
 27271399 nodes
 12 conductors
 Nodally interpolated fields
 with coil fields by integration
 Activated in global coordinates

Field Point Local Coordinates
 Local = Global

FIELD EVALUATIONS

Cartesian (nodal/inte)	267x1079	Cartesian
x=6094.0	y=-5375.0 to 7953.0	z=-33005.0 to 20960.0

Model 91 – Step IV Solenoid 240 MeV/c – 5 gauss scale
 South Wall (external)

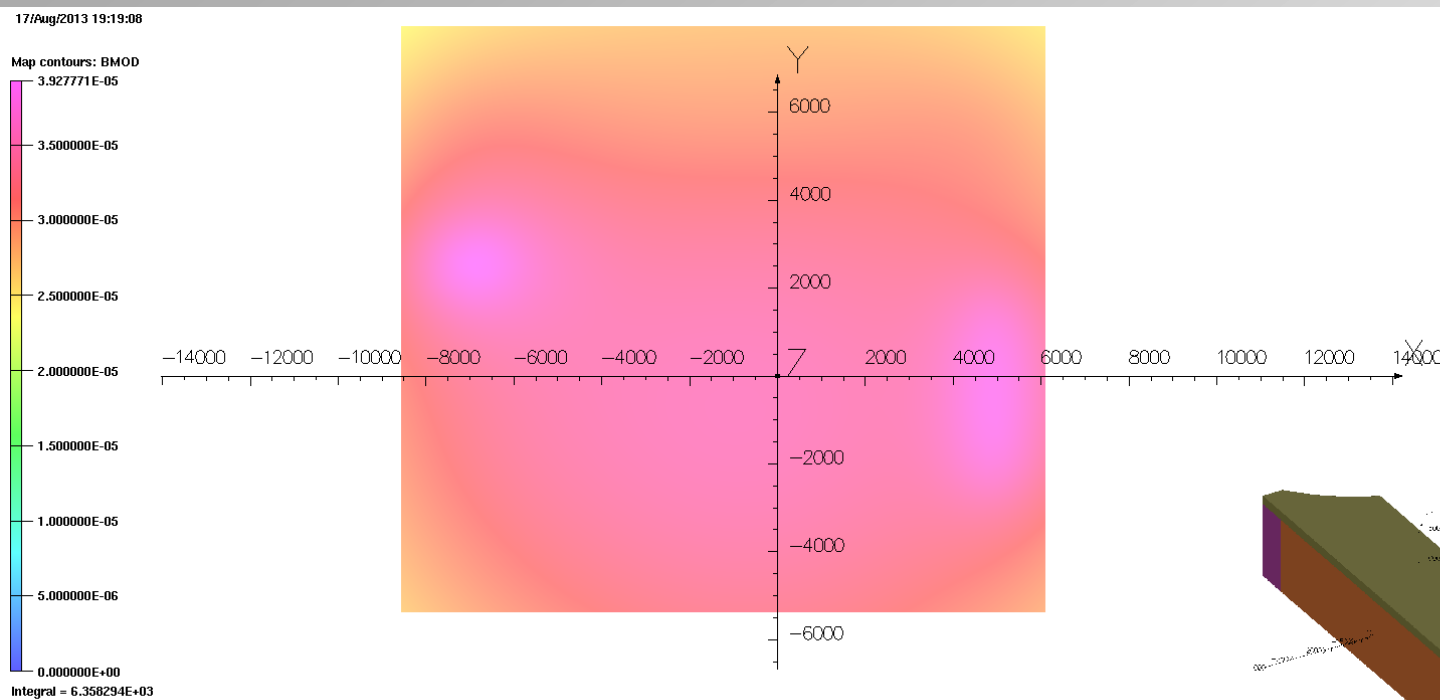

UNITS

Length	mm
Magn Flux Density	T
Magnetic Field	A/m
Magn Scalar Pot	A
Current Density	A/mm ²
Power	W
Force	N

MODEL DATA

Hall_Test_91.op3
 Magnetostatic (TOSCA)
 Nonlinear materials
 Simulation No 1 of 1
 15907802 elements
 27271399 nodes
 12 conductors
 Nodally interpolated fields
 with coil fields by integration
 Activated in global coordinates

Field Point Local Coordinates

Local = Global

FIELD EVALUATIONS

Cartesian	CARTESIAN	293x267	Cartesian
(nodal/inte)			
x=-8567.0 to 6094.0		y=7953.0 to -5375.0	z=20960.0

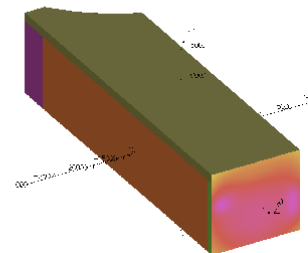

Model 91 – Step IV Solenoid 240 MeV/c – MAX SCALE 0.4 gauss
 West Wall (external)

17/Aug/2013 19:18:47

Map contours: BMOD
 5.000000E-04
 4.500000E-04
 4.000000E-04
 3.500000E-04
 3.000000E-04
 2.500000E-04
 2.000000E-04
 1.500000E-04
 1.000000E-04
 5.000000E-05
 0.000000E+00
 Integral = 1.177512E+05

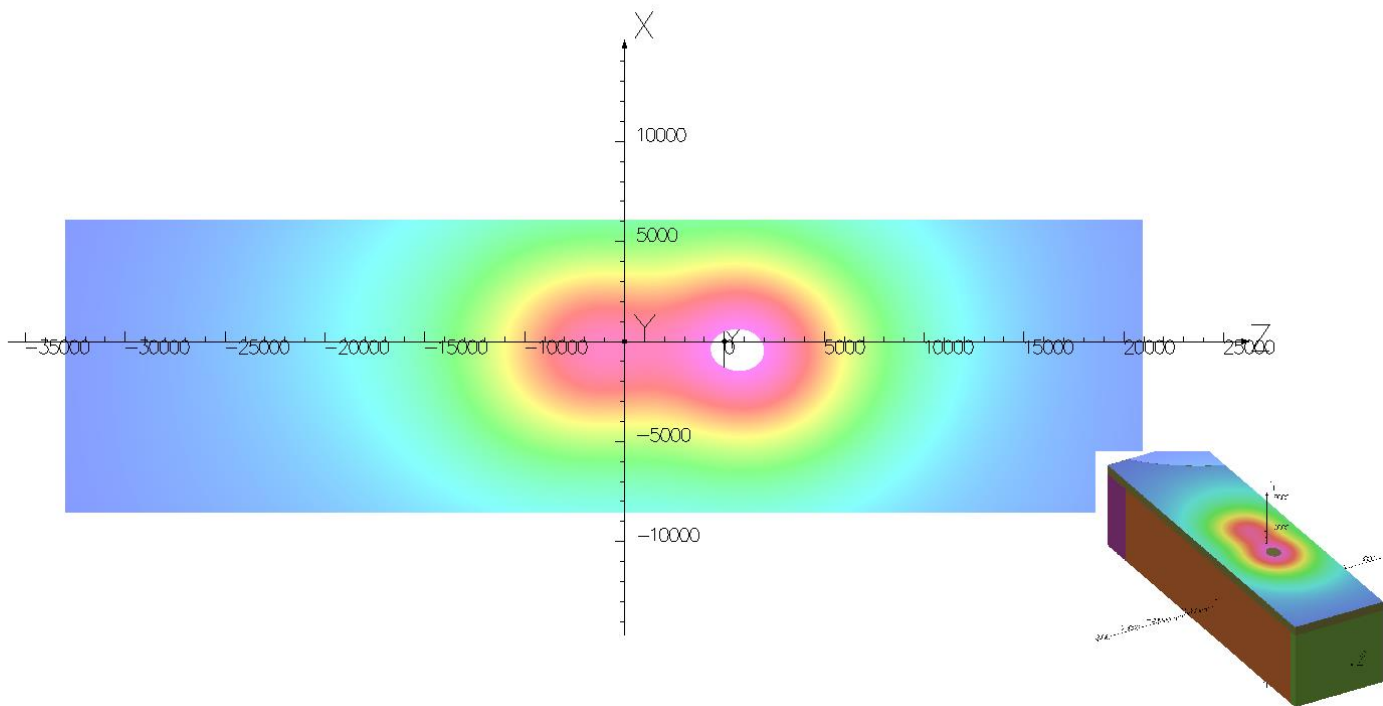

UNITS	
Length	mm
Magn Flux Density T	T
Magnetic Field	A/m
Magn Scalar Pot	A
Current Density	A/mm ²
Power	W
Force	N

MODEL DATA	
Hall_Test_91.op3	
Magnetostatic (TOSCA)	
Nonlinear materials	
Simulation No 1 of 1	
15907802 elements	
27271399 nodes	
12 conductors	
Nodally interpolated fields with coil fields by integration	
Activated in global coordinates	

Field Point Local Coordinates	
Local = Global	

FIELD EVALUATIONS	
Cartesian CARTESIAN	1079x293 Cartesian
(nodal/inte)	
x=-8567.0 to 6094.0	y=7953.0 z=-33005.0 to 20960.0

Model 91 – Step IV Solenoid 240 MeV/c –5 Gauss Scale
 Roof (external)

20/Jul/2013 18:10:16

Map contours: BMOD
 1.000000E-03
 9.000000E-04
 8.000000E-04
 7.000000E-04
 6.000000E-04
 5.000000E-04
 4.000000E-04
 3.000000E-04
 2.000000E-04
 1.000000E-04
 0.000000E+00
 Integral = 1.177512E+05

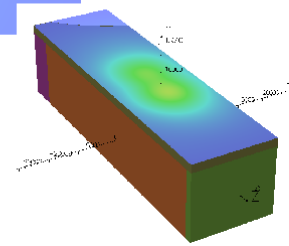
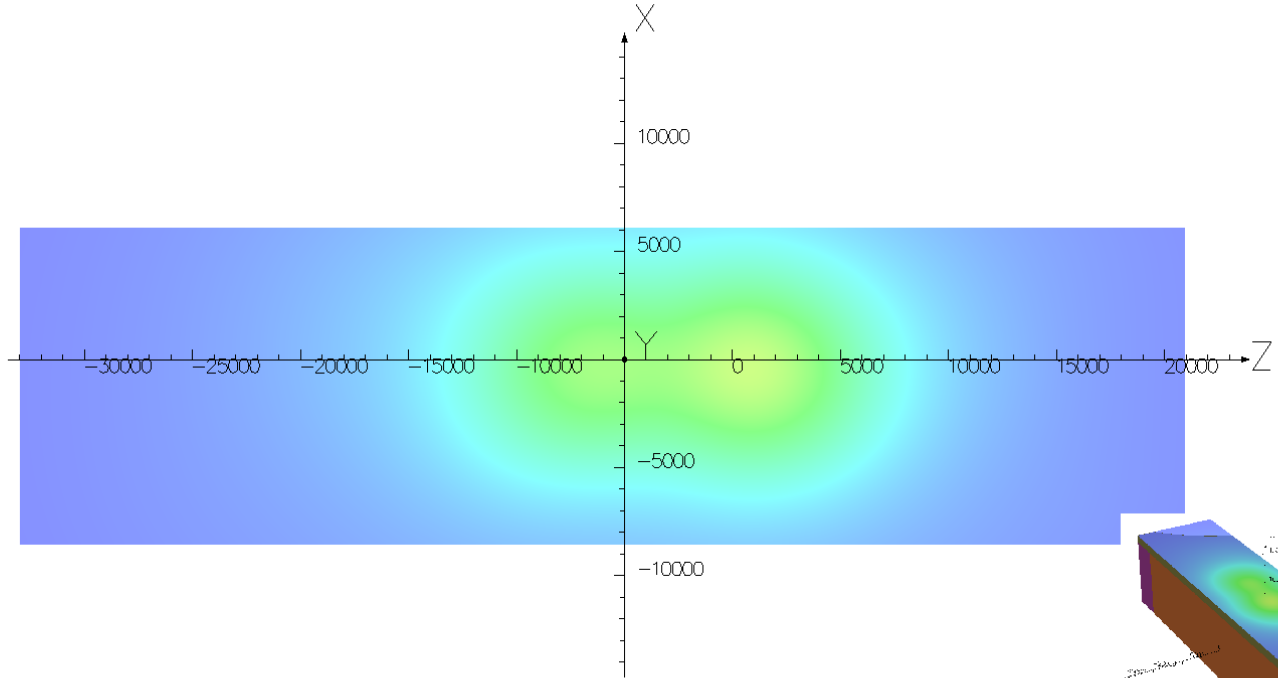

UNITS	
Length	mm
Magn Flux Density	T
Magnetic Field	A/m
Magn Scalar Pot	A
Current Density	A/mm ²
Power	W
Force	N

MODEL DATA	
Hall_Test_91.op3	
Magnetostatic (TOSCA)	
Nonlinear materials	
Simulation No 1 of 1	
15907802 elements	
27271399 nodes	
12 conductors	
Nodally interpolated fields	
with coil fields by integration	
Activated in global coordinates	

Field Point Local Coordinates	
Local = Global	

FIELD EVALUATIONS	
Cartesian CARTESIAN	1079x293 Cartesian
(nodal/inte)	
x=-8567.0 to	y=7953.0 z=-33005.0 to
6094.0	20960.0

Model 91 – Step IV Solenoid 240 MeV/c –10 Gauss Scale
 Roof (external)

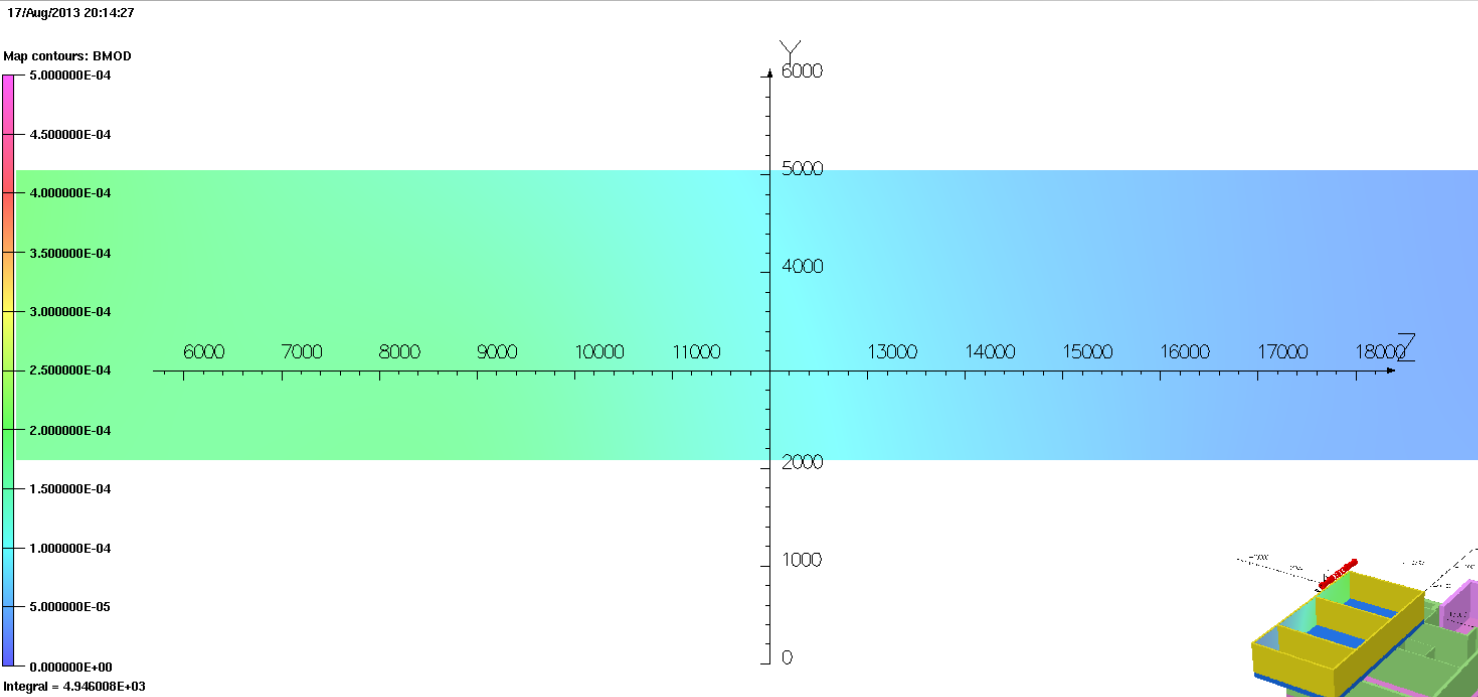

UNITS

Length	mm
Magn Flux Density	T
Magnetic Field	A/m
Magn Scalar Pot	A
Current Density	A/mm ²
Power	W
Force	N

MODEL DATA

Hall_Test_91.op3
 Magnetostatic (TOSCA)
 Nonlinear materials
 Simulation No 1 of 1
 15907802 elements
 27271399 nodes
 12 conductors
 Nodally interpolated fields
 with coil fields by integration
 Activated in global coordinates

Field Point Local Coordinates

Local = Global

FIELD EVALUATIONS

Cartesian	CARTESIAN (nodal/inte)	59x301	Cartesian
	x=6100.0	y=2080.0 to 5050.0	z=4280.0 to 19350.0

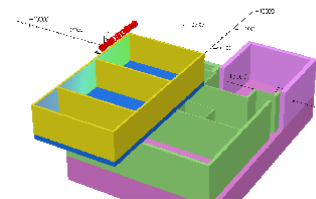

Model 91 – Step IV Solenoid 240 MeV/c –5 Gauss Scale
 ISIS control Rooms North Side (MICE South Wall Side)

17/Aug/2013 20:14:19

Map contours: BMOD

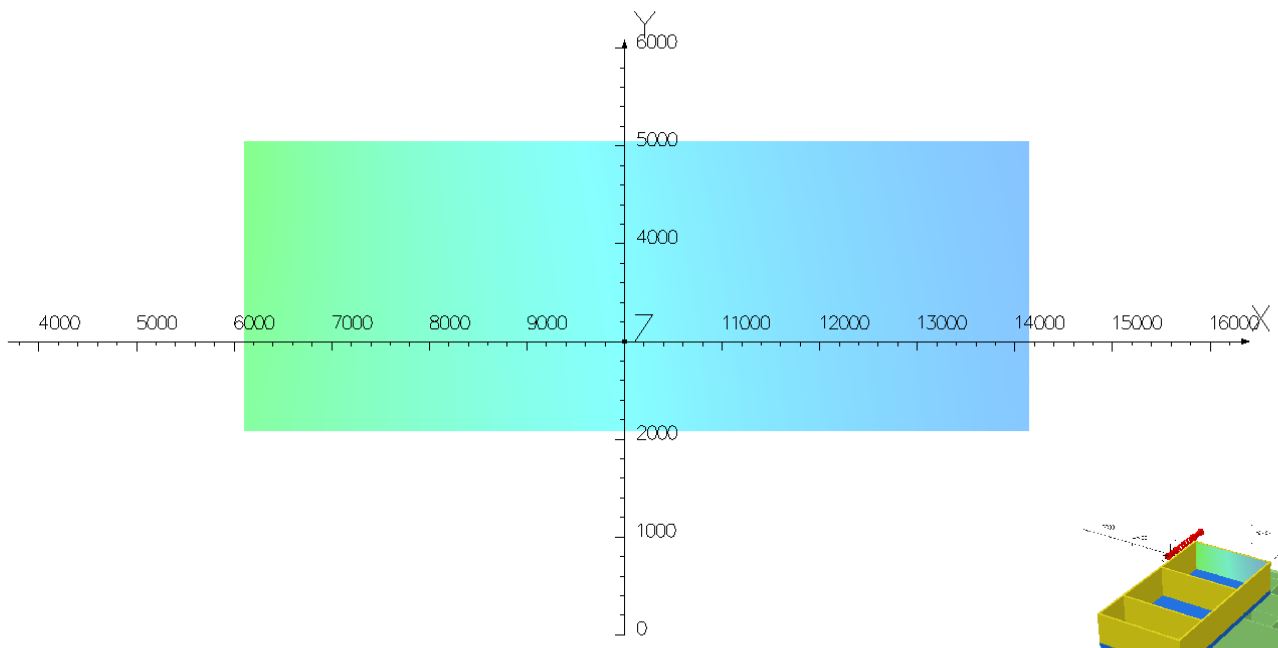
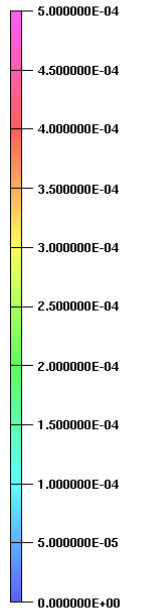

Integral = 2.478577E+03

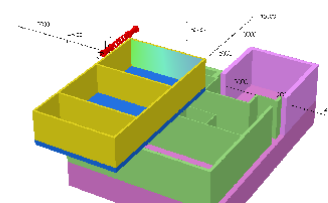

UNITS		
Length	mm	
Magn Flux Density	T	
Magnetic Field	A/m	
Magn Scalar Pot	A	
Current Density	A/mm ²	
Power	W	
Force	N	

MODEL DATA		
Hall_Test_91.op3		
Magnetostatic (TOSCA)		
Nonlinear materials		
Simulation No 1 of 1		
15907802 elements		
27271399 nodes		
12 conductors		
Nodally interpolated fields with coil fields by integration		
Activated in global coordinates		

Field Point Local Coordinates		
Local = Global		

FIELD EVALUATIONS		
Cartesian	CARTESIAN	161x59
	(nodal/inte)	Cartesian
	x=6100.0 to	y=5050.0 to
	14150.0	2080.0
		z=4280.0

Model 91 – Step IV Solenoid 240 MeV/c –5 Gauss Scale
ISIS control Rooms East

17/Aug/2013 20:14:00

Map contours: BMOD

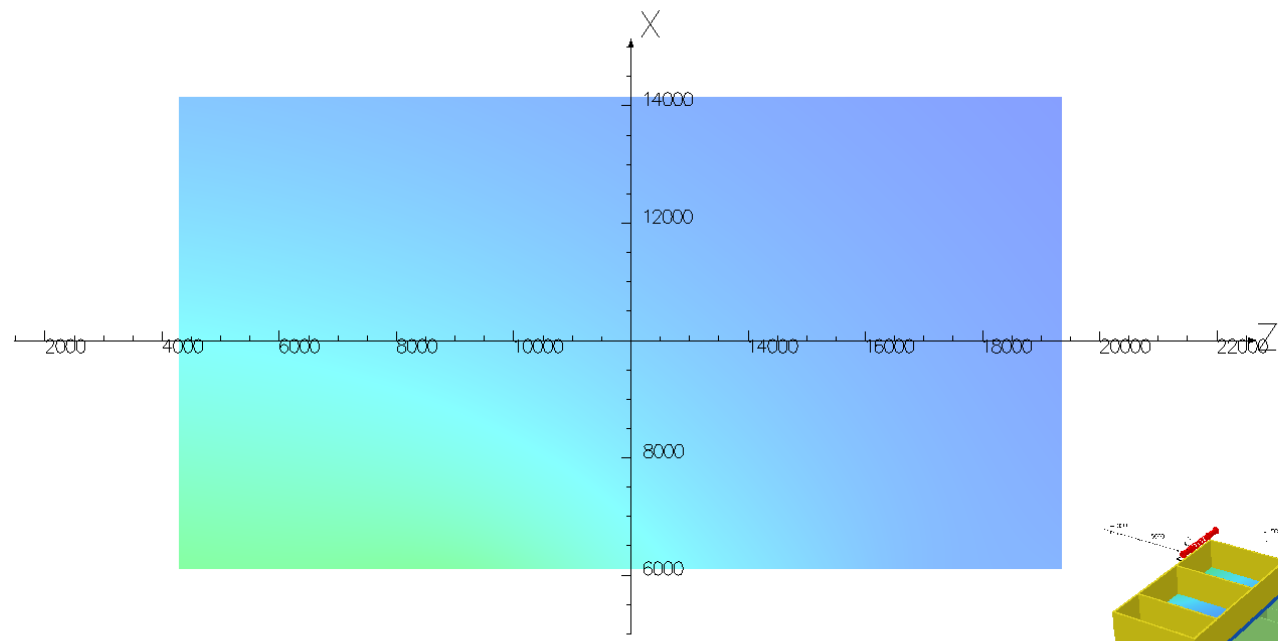
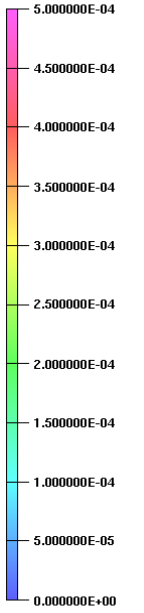

Integral = 8.248922E+03

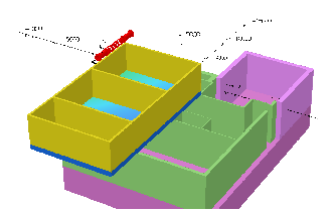

UNITS		
Length	mm	
Magn Flux Density	T	
Magnetic Field	A/m	
Magn Scalar Pot	A	
Current Density	A/mm ²	
Power	W	
Force	N	

MODEL DATA		
Hall_Test_91.op3		
Magnetostatic (TOSCA)		
Nonlinear materials		
Simulation No 1 of 1		
15907802 elements		
27271399 nodes		
12 conductors		
Nodally interpolated fields with coil fields by integration		
Activated in global coordinates		

Field Point Local Coordinates		
Local = Global		

FIELD EVALUATIONS		
Cartesian	CARTESIAN	301x161 Cartesian
	(nodal/inte)	
	x=6100.0 to	y=2080.0 z=4280.0 to
	14150.0	19350.0

Model 91 – Step IV Solenoid 240 MeV/c –5 Gauss Scale ISIS control Rooms Floor

17/Aug/2013 20:14:12

Map contours: BMOD

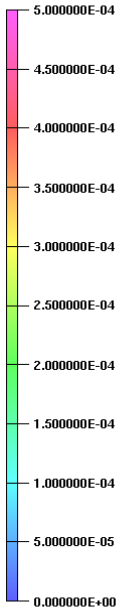

Integral = 7.501344E+03

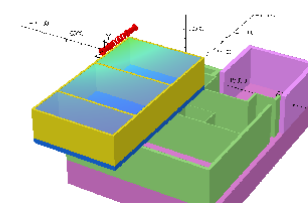
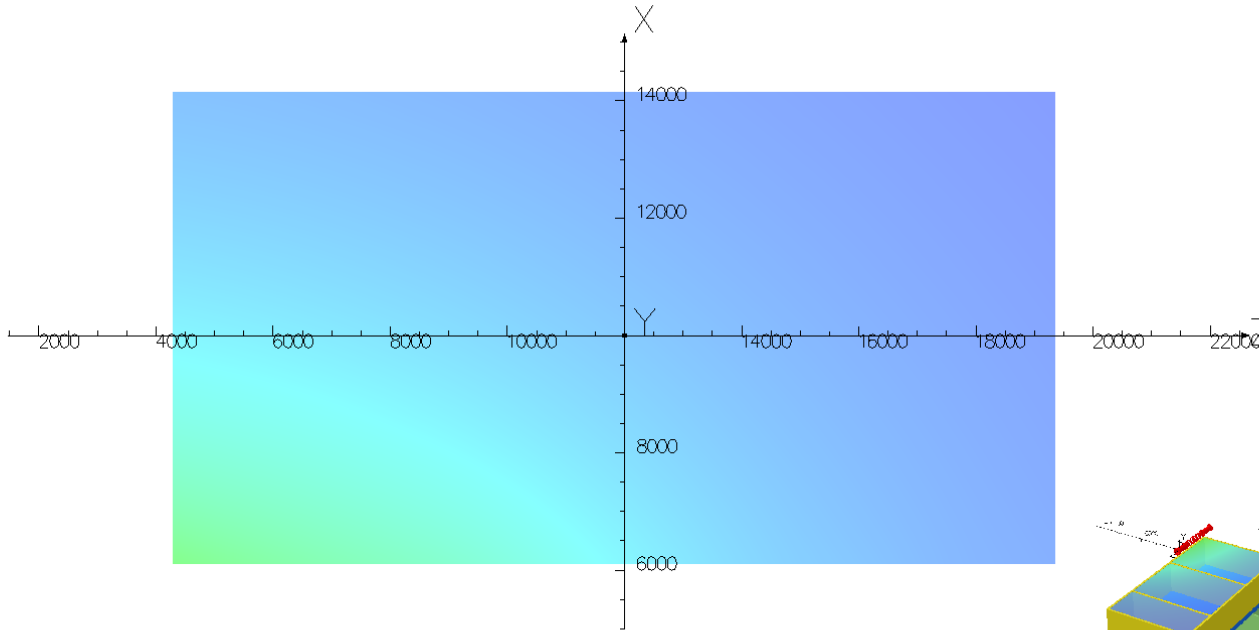

UNITS

Length	mm
Magn Flux Density	T
Magnetic Field	A/m
Magn Scalar Pot	A
Current Density	A/mm ²
Power	W
Force	N

MODEL DATA
 Hall_Test_91.op3
 Magnetostatic (TOSCA)
 Nonlinear materials
 Simulation No 1 of 1
 15907802 elements
 27271399 nodes
 12 conductors
 Nodally interpolated fields
 with coil fields by integration
 Activated in global coordinates

Field Point Local Coordinates
 Local = Global

FIELD EVALUATIONS

Cartesian	CARTESIAN (nodal/mte)	301x161	Cartesian
	x=6100.0 to 14150.0		y=5050.0 z=4280.0 to 19350.0

Model 91 – Step IV Solenoid 240 MeV/c –10 Gauss Scale ISIS control Rooms Ceiling

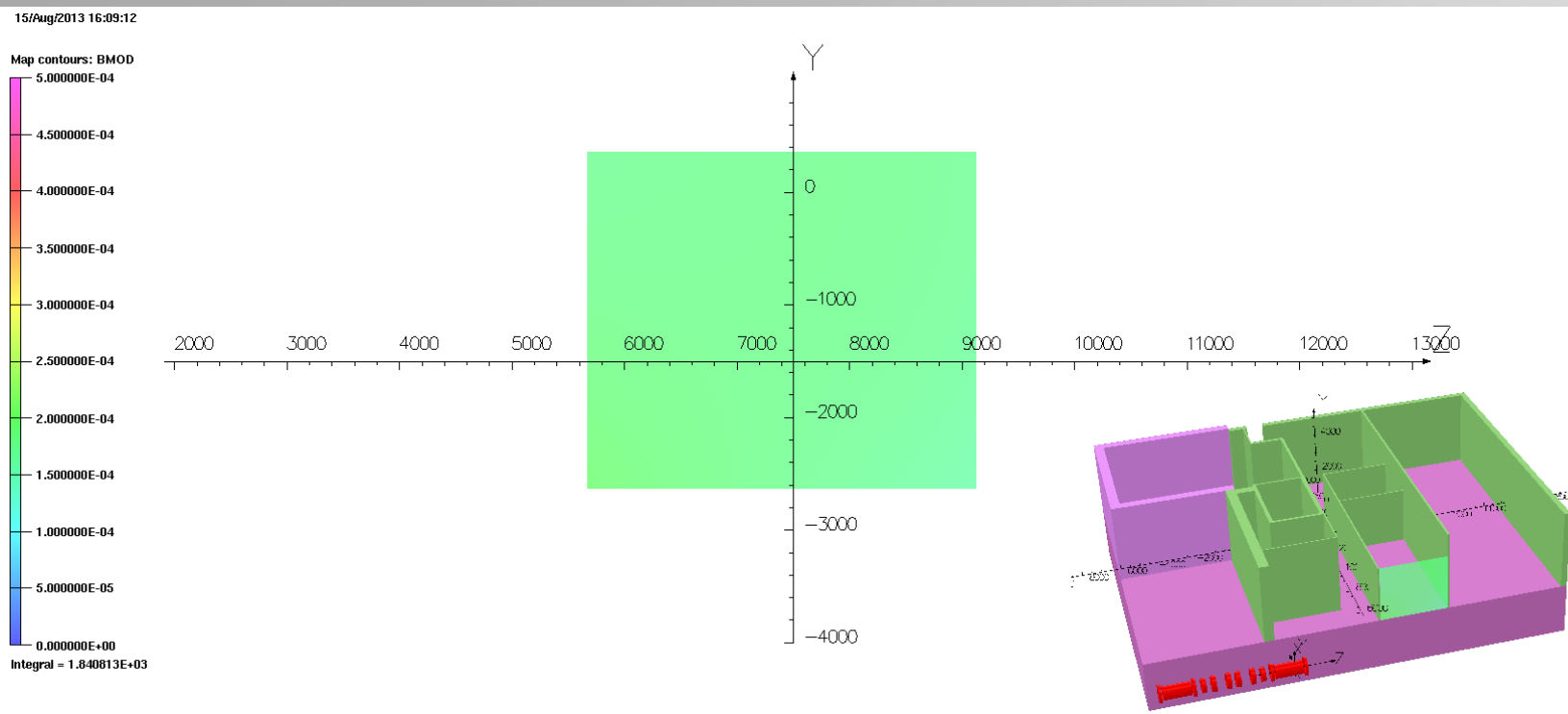

UNITS

Length	mm
Magn Flux Density	T
Magnetic Field	A/m
Magn Scalar Pot	A
Current Density	A/m ²
Power	W
Force	N

MODEL DATA

Hall_Test_91.op3
Magnetostatic (TOSCA)
Nonlinear materials
Simulation No 1 of 1
15907802 elements
27271399 nodes
12 conductors
Nodally interpolated fields
with coil fields by integration
Activated in global coordinates

Field Point Local Coordinates
Local = Global

FIELD EVALUATIONS

Cartesian	CARTESI	60x69	Cartesian
AN			
(nodal/int			
e)			
x=6090.	y=-2630.	z=5670.	
0	0 to	0 to	
	360.0	9125.0	

Model 91 – Step IV Solenoid 240 MeV/c –5 Gauss Scale
MLCR North Wall

17/Aug/2013 21:07:11

Map contours: BMOD

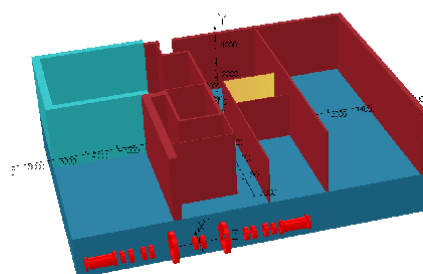
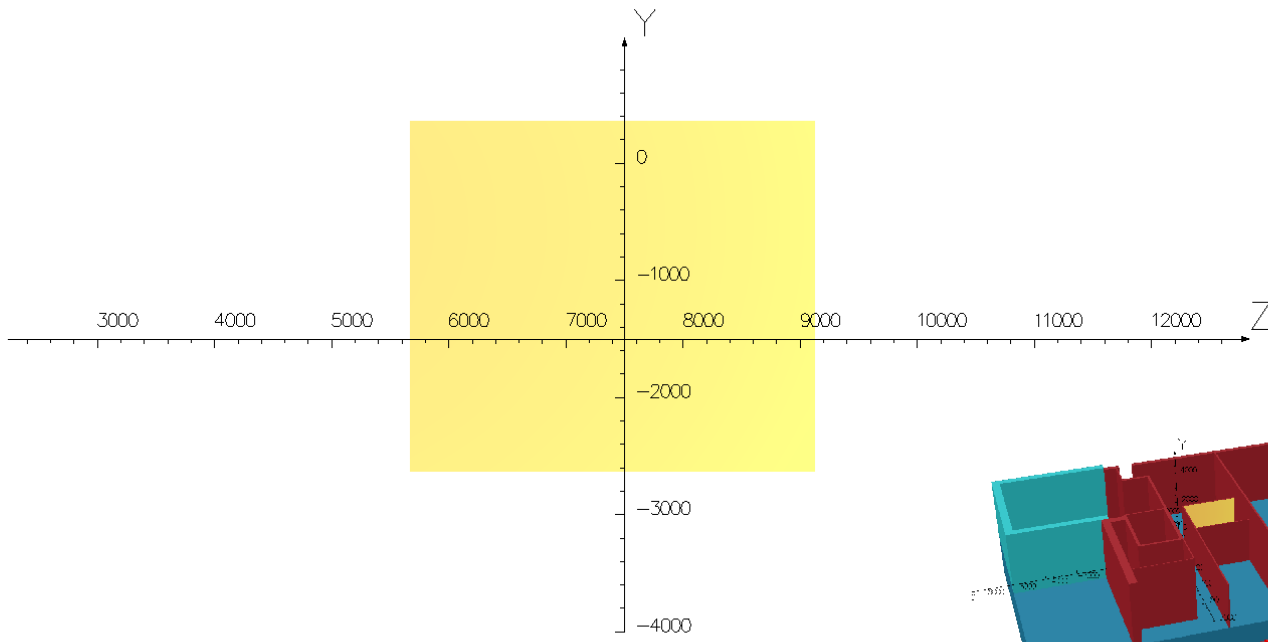
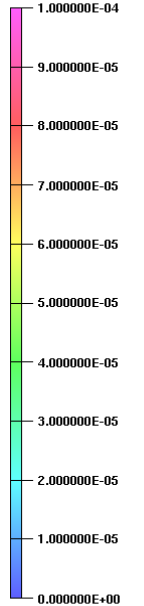

UNITS

Length	mm
Magn Flux Density	T
Magnetic Field	A/m
Magn Scalar Pot	A
Current Density	A/mm ²
Power	W
Force	N

MODEL DATA

Hall_Test_93.op3
Magnetostatic (TOSCA)
Nonlinear materials
Simulation No 1 of 1
17433895 elements
29656623 nodes
18 conductors
Nodally interpolated fields
with coil fields by integration
Activated in global coordinates

Field Point Local Coordinates

Local = Global

FIELD EVALUATIONS

Cartesian	CARTESIAN	60x69	Cartesian
(nodal/inte)			
x=16300.0	y=-2630.0 to		z=5670.0 to
	360.0		9125.0

Model 91 – Step IV Solenoid 240 MeV/c –1 Gauss Scale MLCR South Wall

17/Aug/2013 20:33:40

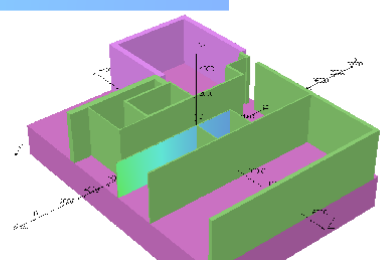
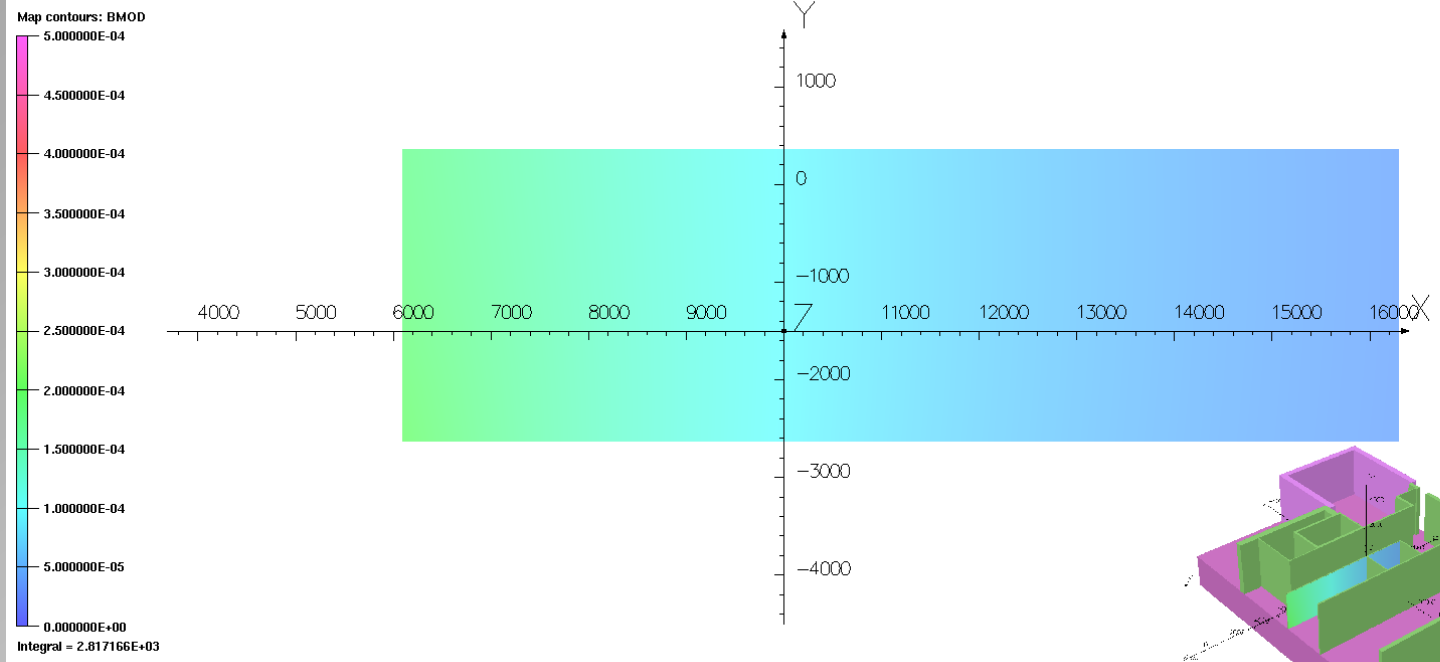

UNITS

Length	mm
Magn Flux Density	T
Magnetic Field	A/m
Magn Scalar Pot	A
Current Density	A/mm ²
Power	W
Force	N

MODEL DATA
 Hall_Test_91.op3
 Magnetostatic (TOSCA)
 Nonlinear materials
 Simulation No 1 of 1
 15907802 elements
 27271399 nodes
 12 conductors
 Nodally interpolated fields
 with coil fields by integration
 Activated in global coordinates

Field Point Local Coordinates
 Local = Global

FIELD EVALUATIONS

Cartesian	CARTESIAN (nodal/inte)	204x60	Cartesian
x=6090.0 to 16300.0			z=5670.0 to -2630.0

Model 91 – Step IV Solenoid 240 MeV/c –5 Gauss Scale MLCR East Wall

15/Aug/2013 16:09:07

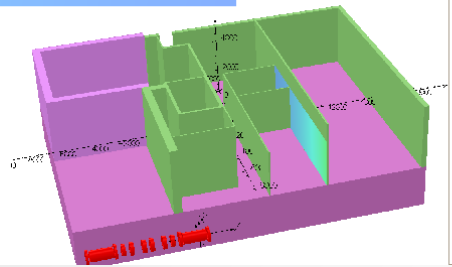
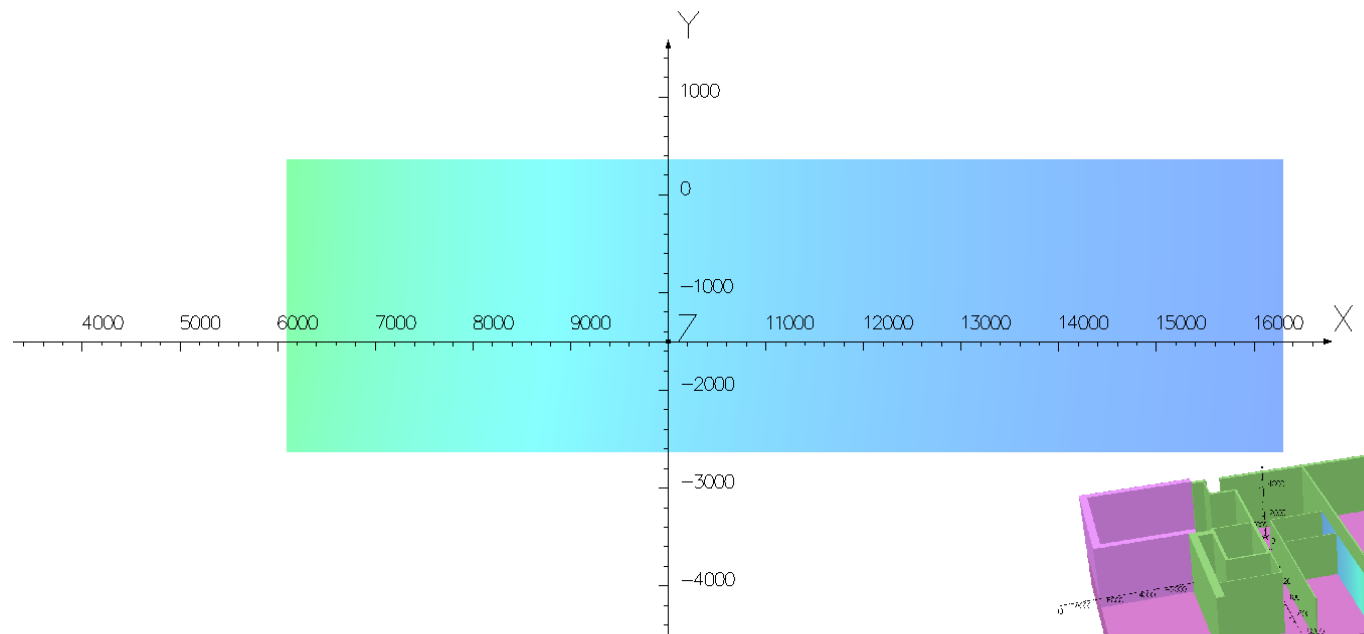
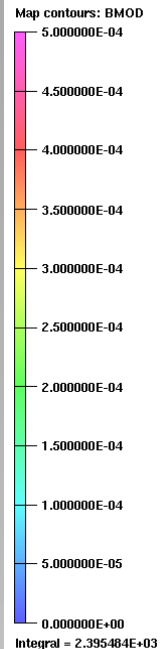

UNITS	
Length	mm
Magn Flux Density T	
Magnetic Field	A/m
Magn Scalar Pot	A
Current Density	A/m ²
Power	W
Force	N

MODEL DATA	
Hall_Test_91.op3	
Magnetostatic (TOSCA)	
Nonlinear materials	
Simulation No 1 of 1	
15907802 elements	
27271399 nodes	
12 conductors	
Nodally interpolated fields with coil fields by integration	
Activated in global coordinates	

Field Point Local Coordinates	
Local = Global	

FIELD EVALUATIONS	
Cartesian	CARTESI 204x60 Cartesian
AN (nodal/int e)	
x=6090	y=360.0 z=9125.0
0 to	to 0
16300.0	-2630.0

Model 91 – Step IV Solenoid 240 MeV/c –5 Gauss Scale MLCR West Wall



Comments



So we have a lot of plots like this. Additionally work has been done to go through our 'Fry' list, this is a list of components that may be affected by the stray field, and with some exceptions and a few caveats, most of this doesn't look too troubling for step IV; you will hear about this next.

ISIS have provided us with a list of their equipment that may be at risk. We are in a position to give an indication of predicted air fields in these regions. However the presence and effect of small quantities of ferromagnetic materials in these areas that are not included in the model may alter the field at a localised level—this represents an uncertainty.

If the baseline solution was to be adopted we would need to ascertain the impact of these plots upon the ISIS CR and equipment.

So why not recommend the baseline solution? Well I think the answer is RISK. A lot of effort has been put into the model to ensure that technically it is as accurate as it possibly can be. However:

- 1) The hall model still represents an approximation. Approximations have been made with objects and difficult to mesh (steel) objects are not included. Racks are not included. Whilst we understand that this is unlikely to have a large impact upon the model output it still represents an uncertainty.
- 2) The model has not been benchmarked. By benchmarked this is defined as running the hall model on a second code or having experimental measurements to back up and verify the output. We are confident that the model is representative but it is hard to prove.
- 3) The hall model makes assumptions about the magnetic properties of the steel within the hall. Some simple tests have demonstrated that the hall model output does not appear to be hugely dependent upon the assumed BH curves, but that testing was not comprehensive.

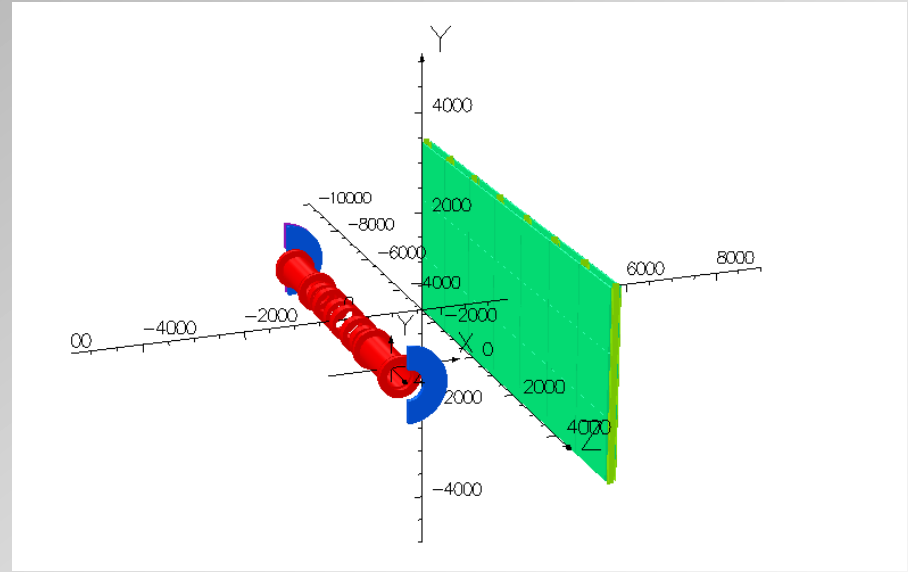

The North and South Shield Walls are modelled as a dual skinned homogenous sheets of tenon steel. In reality they are built of a plate structure bolted to a steel framework with significant gaps between the plates. These gaps are of concern as they may reduce the effectiveness of the shield wall.

To try and understand the effect of these gaps a model was built that modelled a more realistic section of a shield wall. I'm not going to include a lot of details here about the model because of time but this material is available on the magnetics website.



Shield Wall Model



The 'realistic' models are large, complex, they are not 100% representative but are a much better approximation to a real shield wall. This is to some extent still work in progress as I'm still trying to run a few some more models and get some better data on this.

The plot on the next page shows the predicted field 250mm behind the shield wall in one of these models compared with the predicted field 250mm behind the South Shield Wall in model 91.

There is a small discrepancy between the shield location in these models in the x-direction

The shield wall model is ~50% smaller than the real wall (But it can't be made any bigger due to computer memory constraints)

Note that this plot likely demonstrates a worse case scenario as it makes some pessimistic assumptions about the shield wall. It appears that the amount of field leakage is sensitive to the presumed gap between the I-beams and the steel plates (modelled from 0 to 1mm). However It is clear that there is not a 'good' magnetic connection between the plates and the I beams in the MICE hall. I think it would take a measurement to resolve this, something that I don't believe we can do easily.

Comparison Plots of Field Behind Modelled Shield Wall at x=3861 mm (3977 mm) y=0mm

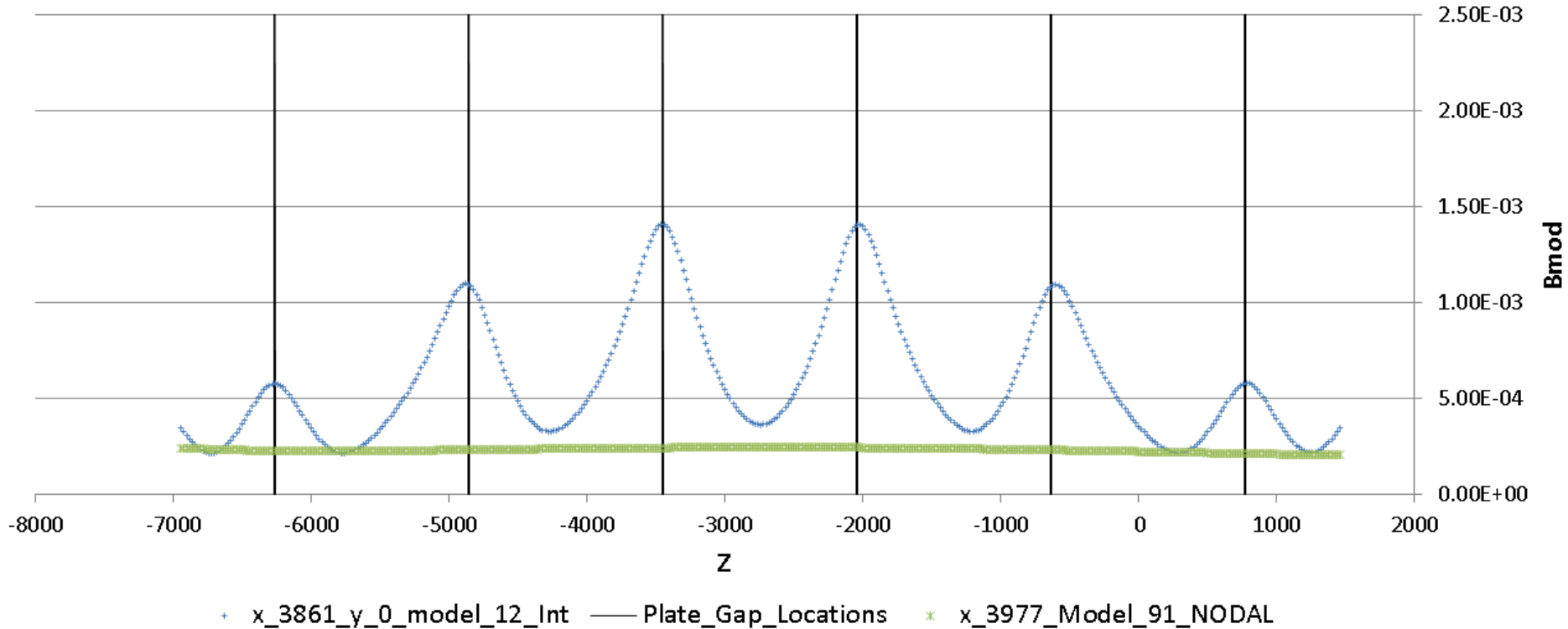

Green line – predicted field 250 mm behind South Shield Wall in model 91
Blue line – predicted field behind the shield wall model with a 1mm plate gap between plates and I beams (which is a worse case)

There is a small discrepancy in the distance of the shield wall from the beam-line between these models (3861 mm vs 3977 mm)

We added a shell of the substation (5300kg steel) to model 91 to ascertain whether this would have an effect on the field in the location of the substation. Very minor changes to the field distribution are predicted. The magnitude of the field in the region of the sub-station doesn't look worrying. This exercise needs repeating for step VI.



I also run some sub-models to ascertain the likely effect of placing holes in the skin of the substation to see what the field would be at the location of the surface mounted instrumentation. The results were encouraging, the instrumentation shouldn't see much more than background field, although there is a slight dependency upon the field direction.

MODEL 113

5 gauss scale @ y=0

240 MeV/c Solenoid

Mode Step IV.

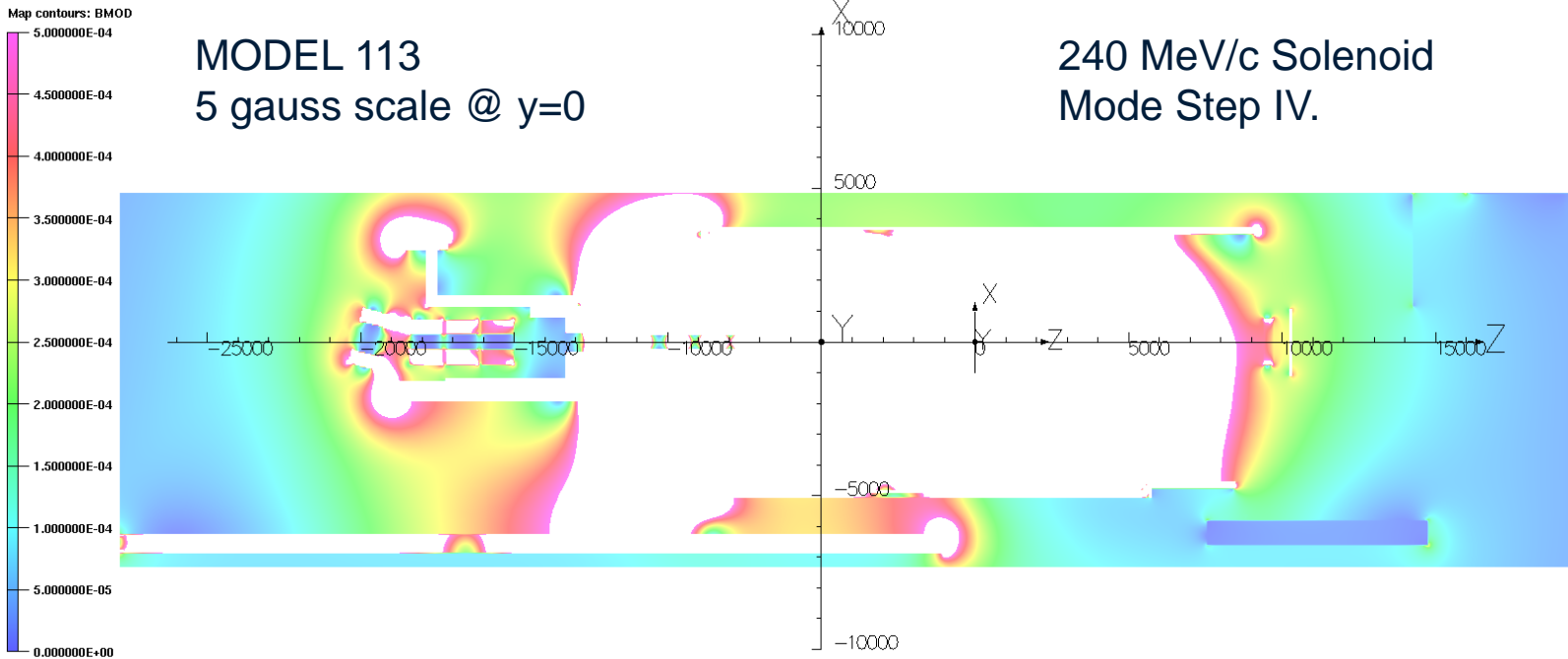

Length	mm
Magn Flux Density	T
Magnetic Field	A/m
Magn Scalar Pot	A
Current Density	A/mm ²
Power	W
Force	N

MODEL DATA
 Hall_Test_113.op3
 Magnetostatic (TOSCA)
 Nonlinear materials
 Simulation No 1 of 1
 50837509 elements
 55943509 nodes
 12 conductors
 Nodally interpolated fields
 with coil fields by integration
 Activated in global coordinates

Field Point Local Coordinates
 Local = Global

FIELD EVALUATIONS
 Cartesian CARTE 952x24 Cartesian
 n SIAN 4 n
 (nodal/inte)
 x=-734 y=0.0 z=-278
 0 to 58.0 to
 4851.0 19736.0

For Comparison:

MODEL 91 – 5 gauss scale

240 MeV/c Solenoid

Mode Step IV.

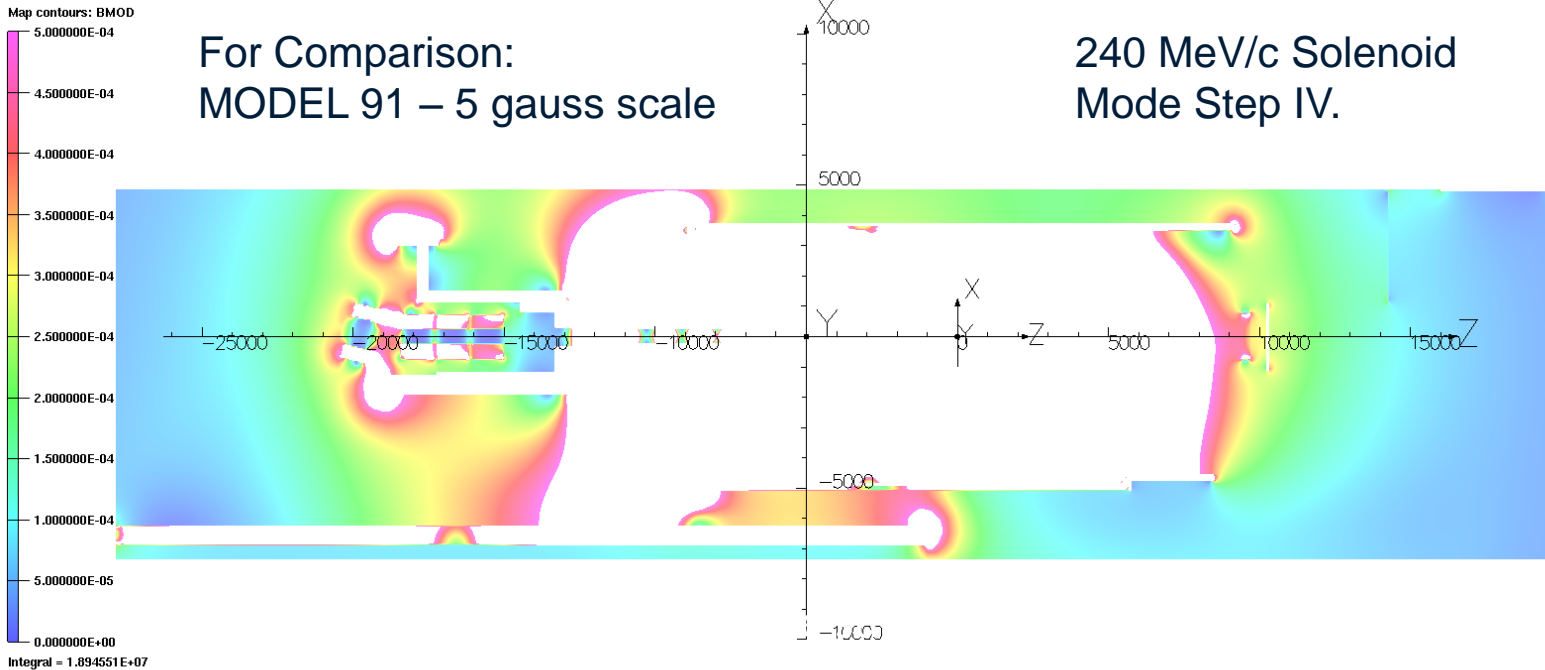

Length	mm
Magn Flux Density	T
Magnetic Field	A/m
Magn Scalar Pot	A
Current Density	A/mm ²
Power	W
Force	N

MODEL DATA
 Hall_Test_91.op3
 Magnetostatic (TOSCA)
 Nonlinear materials
 Simulation No 1 of 1
 15907802 elements
 27271399 nodes
 12 conductors
 Nodally interpolated fields
 with coil fields by integration
 Activated in global coordinates

Field Point Local Coordinates
 Local = Global

FIELD EVALUATIONS
 Cartesian CARTESIA 952x244 Cartesian
 N
 (nodal/inte)
 x=-7343. y=0.0 z=-27858.
 0 to 0 to
 4851.0 19736.0

2500 gauss

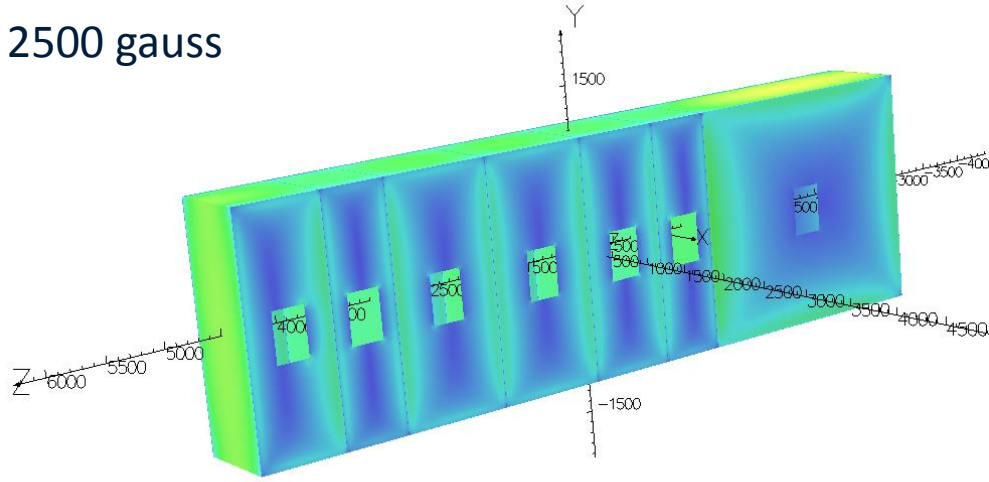

The transformer section is slightly smaller in the model than in reality (aids meshing)

In the sub-model the skin is 2mm thick giving total mass of ~1000kg

10 gauss

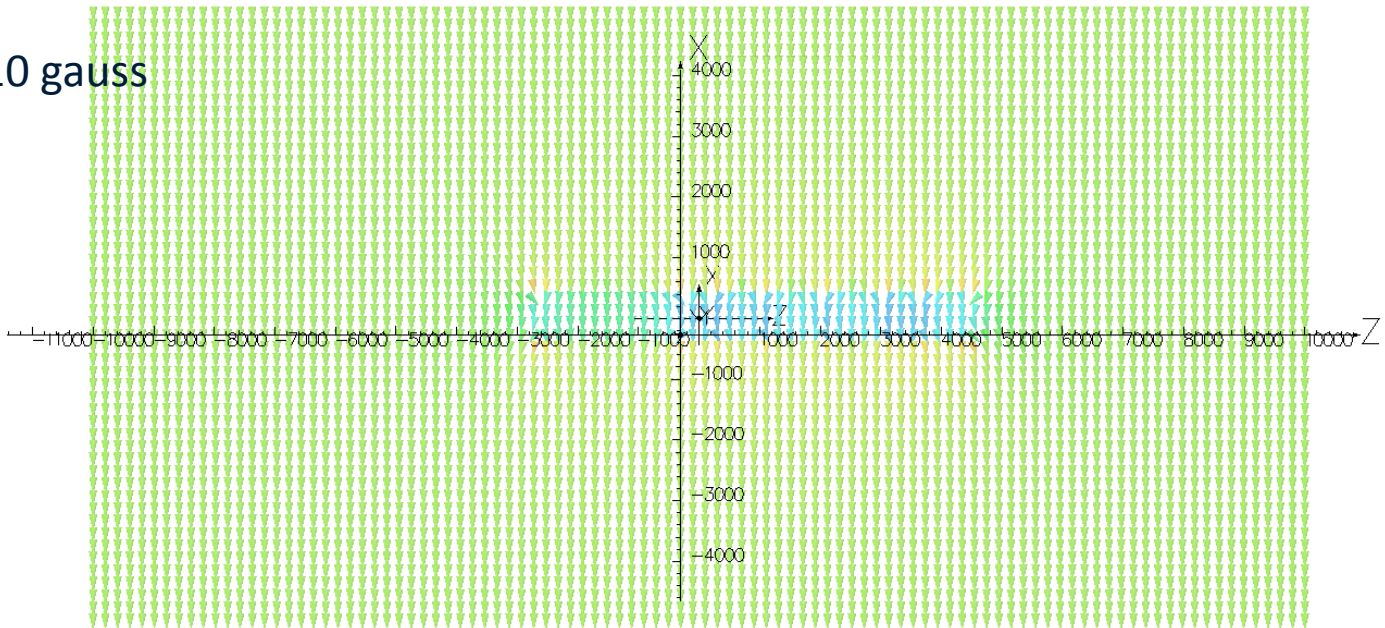

13/Aug/2013 15:47:56

Map contours: BMOD

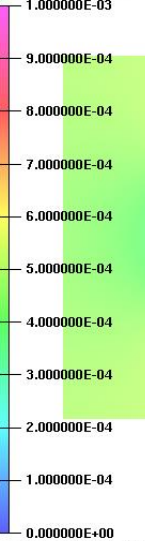

Integral = 1.005260E+04

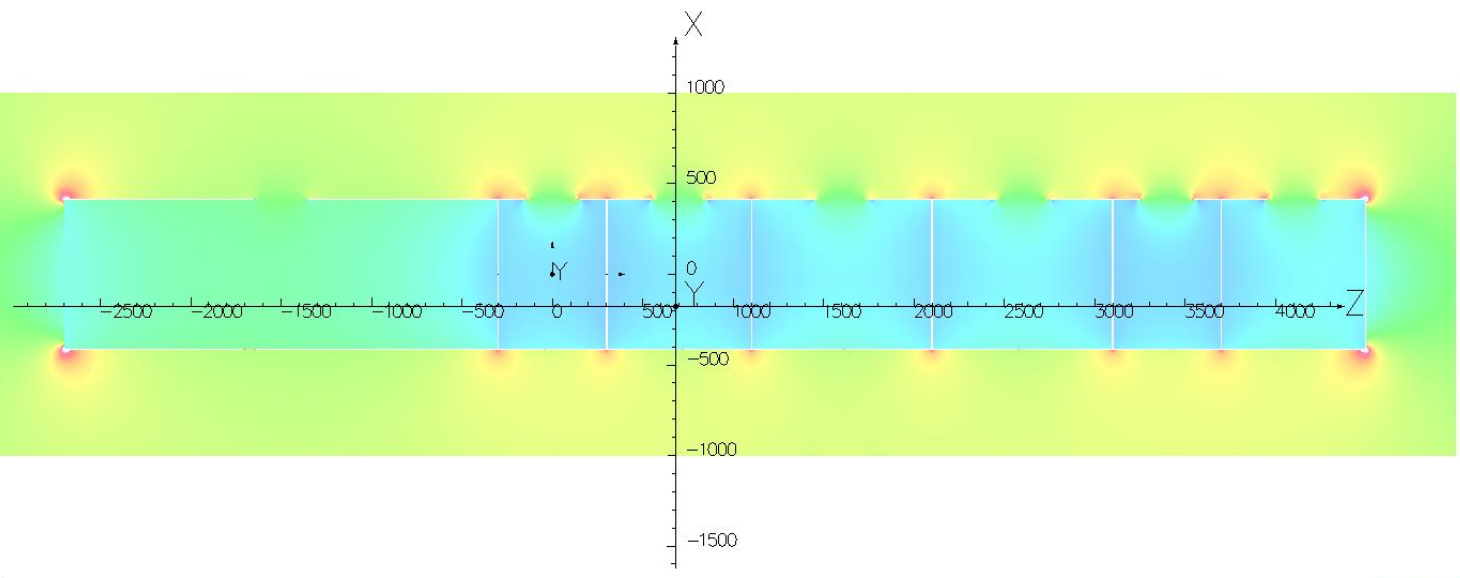

UNITS

Length	mm
Magn Flux Density T	
Magnetic Field	A/m
Magn Scalar Pot	A
Current Density	A/mm ²
Power	W
Force	N

MODEL DATA
 Sub_Station_02_Model_14.op3
 Magnetostatic (TOSCA)
 Nonlinear materials
 Simulation No 1 of 1
 16145880 elements
 28854775 nodes
 External field: -397.8874, 0.0, 0.0
 Nodally interpolated fields
 Activated in global coordinates

Field Point Local Coordinates
 Local = Global

FIELD EVALUATIONS

Cartesi	CARTE	2000x	Cartesi
an	SIAN	1000	an
	(nodal)		
x=-100	y=0.0	z=-350	
0.0 to		0.0 to	
1000.0		5000.0	



13/Aug/2013 15:54:07

Map contours: BMOD

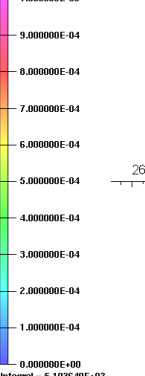

Integral = 5.103640E+02

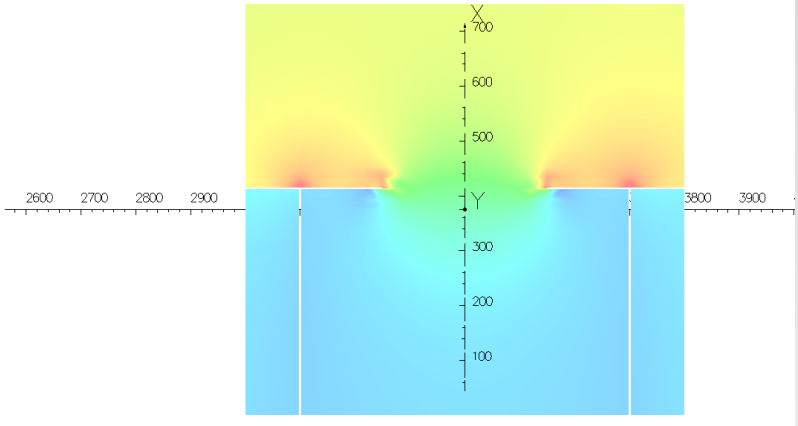

13/Aug/2013 15:55:49

Map vectors: B

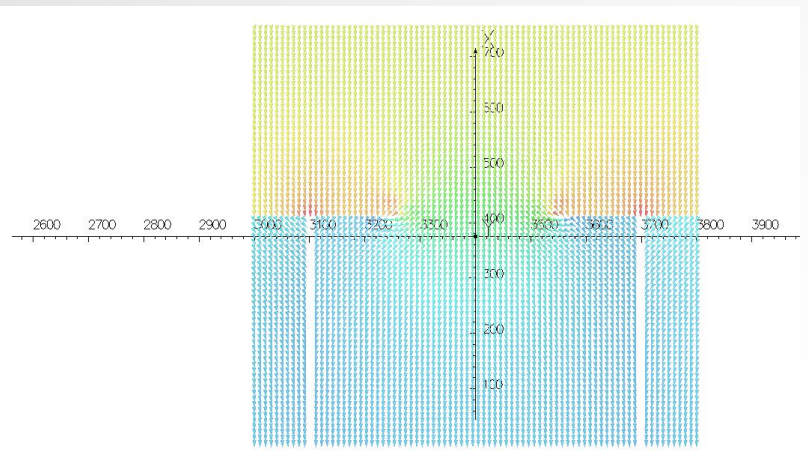
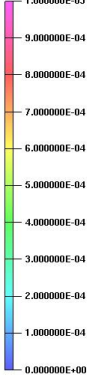

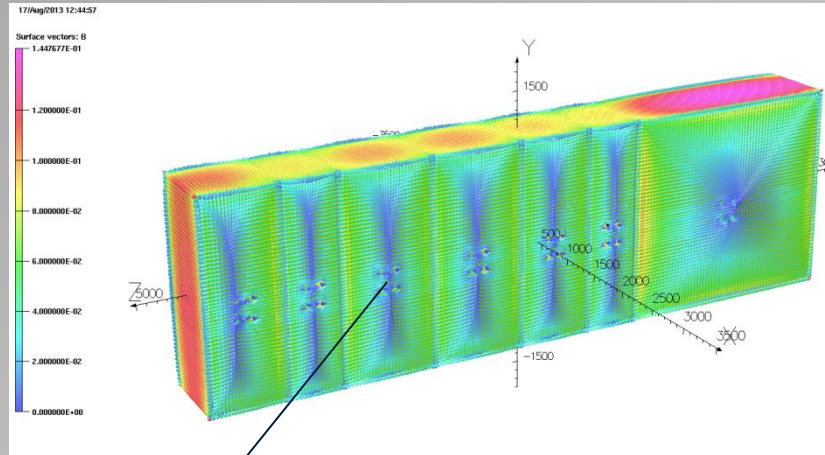

External field of 5 gauss applied to the sub-model

Field perpendicular to sub-station (South to North)

~1500 gauss

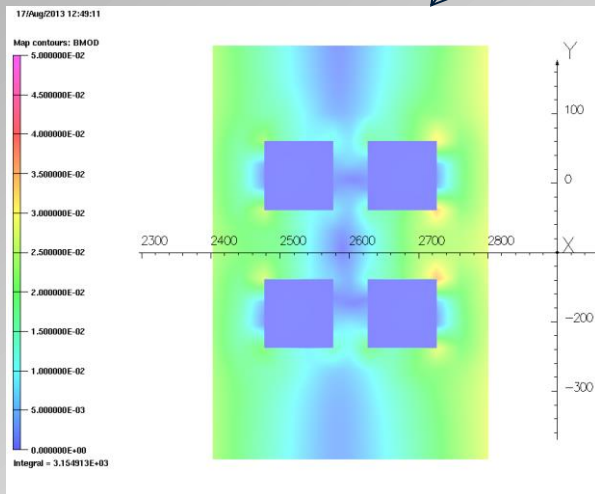

500 gauss

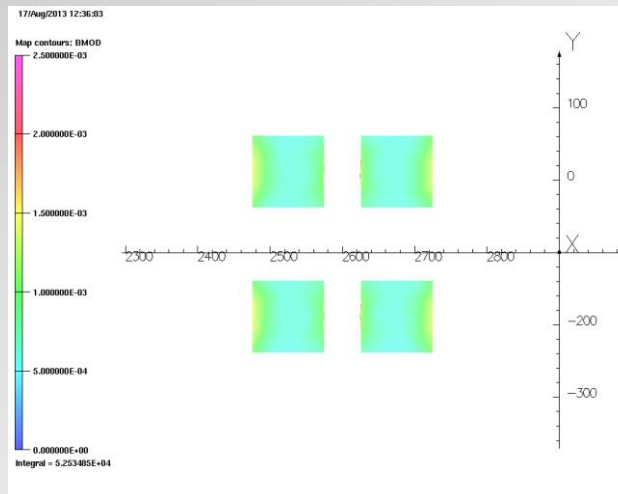

25 gauss

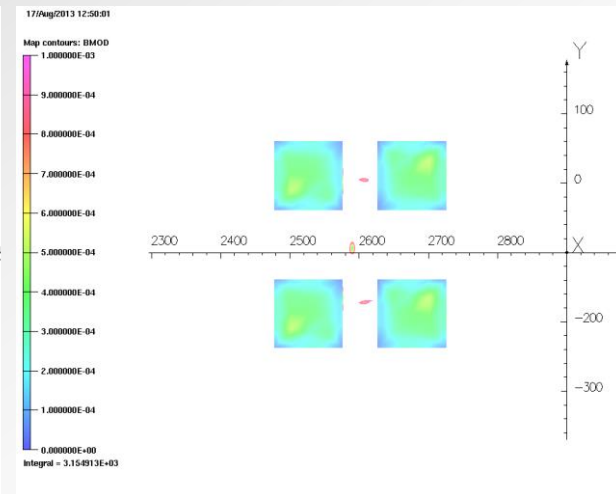

10 gauss



How much does the picture change at Step VI?



The primary focus has been on Step IV, as this represents an important milestone for the MICE experiment. However, these models have also been run for Step VI, so how do they compare?

There has been much less analysis done at Step VI on the hall model but it is clear that the situation gets worse as the cooling channel is extended.

Generally the stray field is pushed West, and the East Stray field doesn't change too much. This result isn't too surprising as the cooling channel is extended in the westward direction.

The 5 gauss line is generally contained within the MICE hall but there are a couple of hotspots. The field external to the MICE hall does increase but other plots - not shown here - indicate that the increase is perhaps not as much as was initially anticipated.

The sub station is clearly going to be vulnerable in Step VI, although of course the situation is likely to be different with a return yoke!

Length	mm
Magn Flux Density	T
Magnetic Field	A/m
Magn Scalar Pot	A
Current Density	A/mm ²
Power	W
Force	N

MODEL DATA
Hall_Test_91.op3
Magnetostatic (TOSCA)
Nonlinear materials
Simulation No 1 of 1
15907802 elements
27271399 nodes
12 conductors
Nodally interpolated fields
with coil fields by integration
Activated in global coordinates

Field Point Local Coordinates
Local = Global

FIELD EVALUATIONS

Cartesian	CARTESIA	952x244	Cartesian
N			
(nodal/int			
e)			
x=-7343.0	y=0.0	z=-27858.0	
0 to		0 to	
4851.0		19736.0	

MODEL 91 – 5 gauss scale

240 MeV/c Solenoid Mode Step IV.

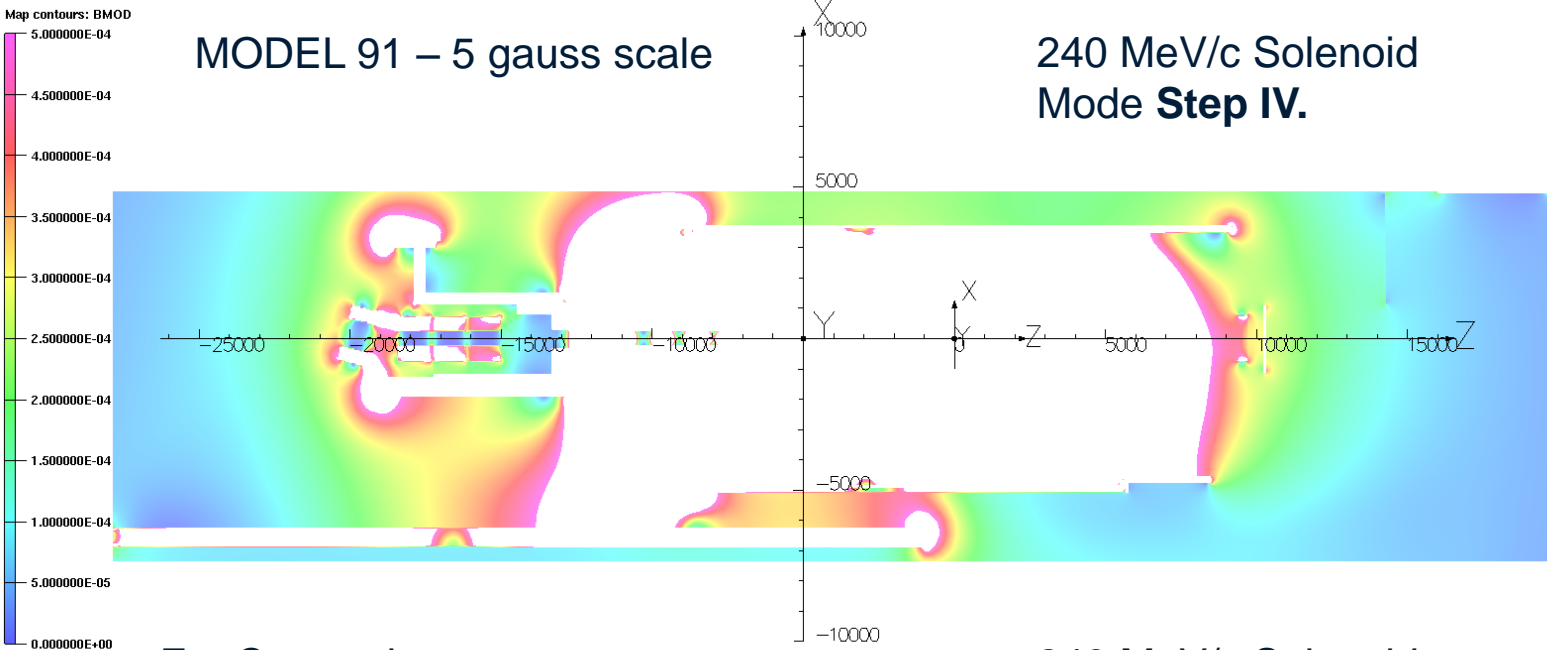

Integral = 1.894551E+07
For Comparison:
MODEL 93 – 5 gauss scale

240 MeV/c Solenoid Mode Step VI.

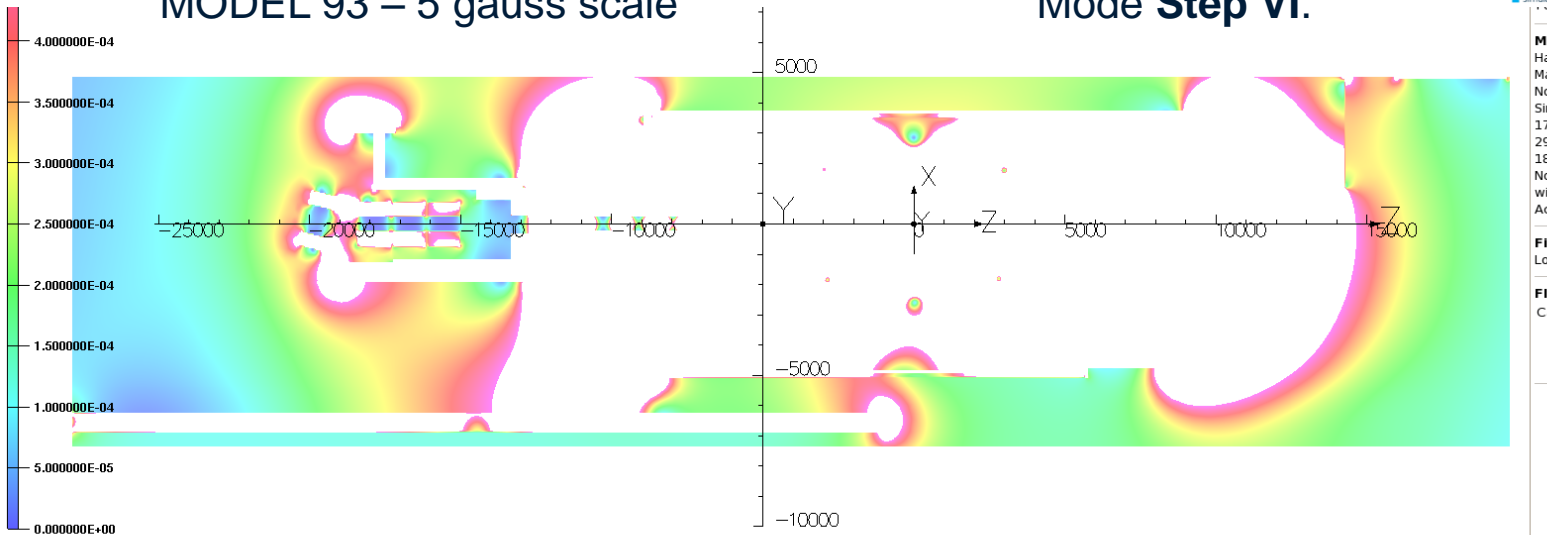

Integral = 2.743122E+07



MODEL DATA
Hall_Test_93.op3
Magnetostatic (TOSCA)
Nonlinear materials
Simulation No 1 of 1
17433895 elements
29656623 nodes
18 conductors
Nodally interpolated fields
with coil fields by integration
Activated in global coordinates

Field Point Local Coordinates
Local = Global

FIELD EVALUATIONS

Cartesian	CARTESIAN	952x244	Cartesian
(nodal/inte			
x=-7343.0 to	y=0.0	z=-27858.0 to	
4851.0		19736.0	



23/Jun/2013 14:49:44

Map contours: BMOD

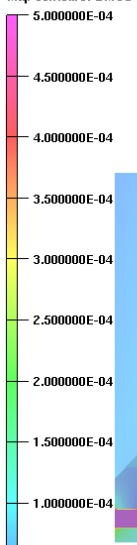

MODEL 91 – 5 gauss scale

240 MeV/c Solenoid Mode Step IV.

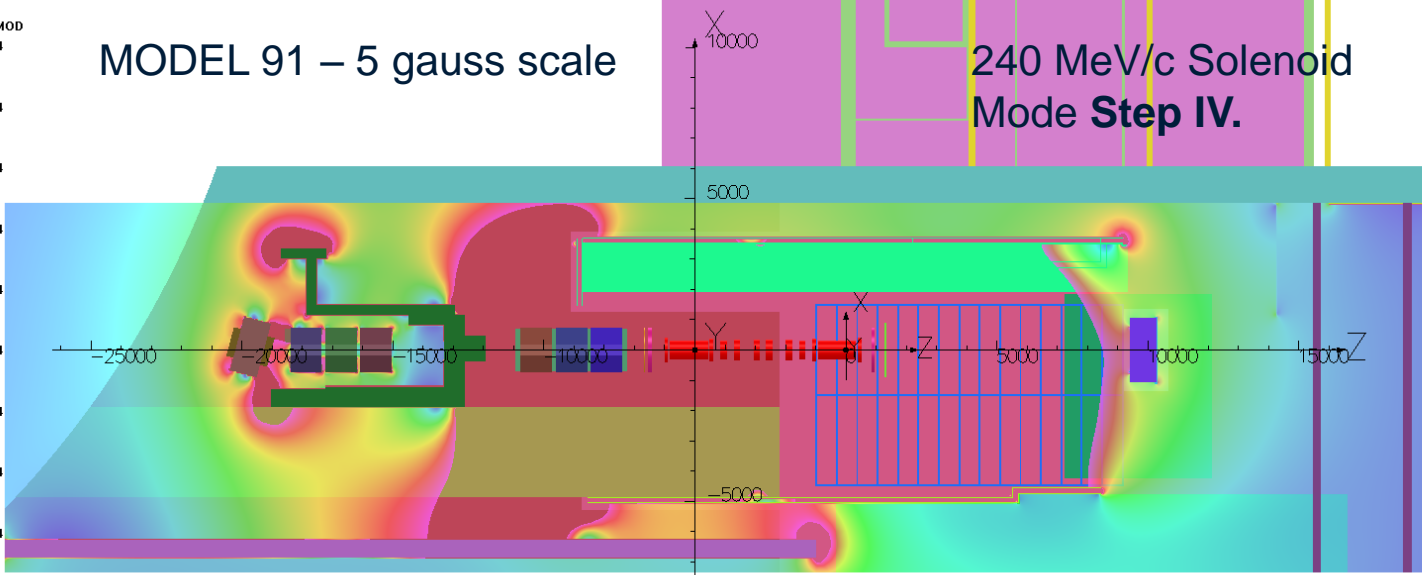

UNITS

Length	mm
Magn Flux Density T	
Magnetic Field	A/m
Magn Scalar Pot	A
Current Density	A/mm ²
Power	W
Force	N

MODEL DATA

Hall_Test_91.op3
 Magnetostatic (TOSCA)
 Nonlinear materials
 Simulation No 1 of 1
 15907802 elements
 27271399 nodes
 12 conductors
 Nodally interpolated fields
 with coil fields by integration
 Activated in global coordinates

Field Point Local Coordinates
Local = Global

FIELD EVALUATIONS

Cartesian CARTESIA 952x244 Cartesian
 N
 (nodal/int
 e)
 x=-7343. y=0.0 z=-27858.
 0 to 4851.0 0 to 19736.0

25/Jun/2013 16:17:04

Map contours: BMOD

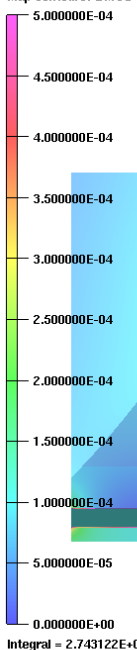

For Comparison: MODEL 93 – 5 gauss scale

240 MeV/c Solenoid Mode Step VI.

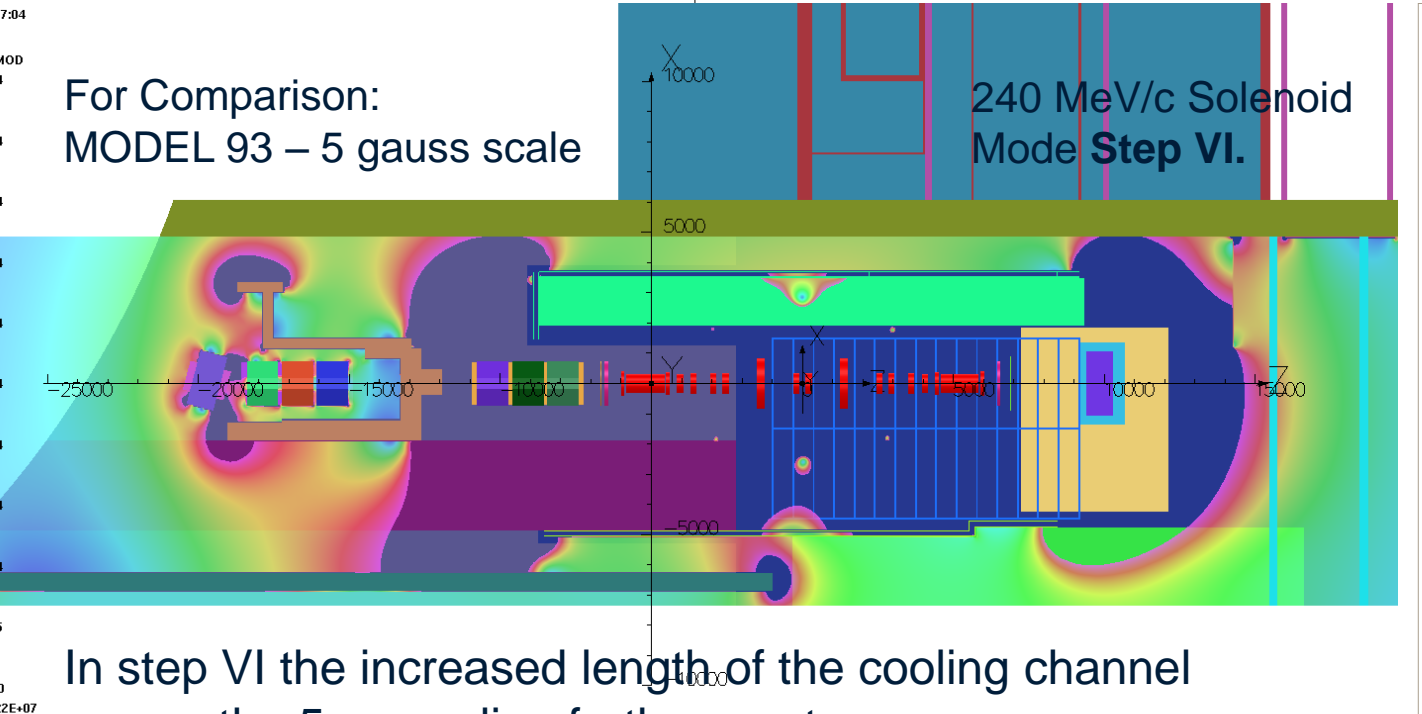

UNITS

Length	mm
Magn Flux Density T	
Magnetic Field	A/m
Magn Scalar Pot	A
Current Density	A/mm ²
Power	W
Force	N

MODEL DATA

Hall_Test_93.op3
 Magnetostatic (TOSCA)
 Nonlinear materials
 Simulation No 1 of 1
 17433895 elements
 29656623 nodes
 18 conductors
 Nodally interpolated fields
 with coil fields by integration
 Activated in global coordinates

Field Point Local Coordinates
Local = Global

FIELD EVALUATIONS

Cartesian CARTESIAN 952x244 Cartesian
 (nodal/inte)
 x=-7343.0 to 4851.0 y=0.0 z=-27858.0 to 19736.0

In step VI the increased length of the cooling channel moves the 5 gauss line further west

Map contours: BMOD

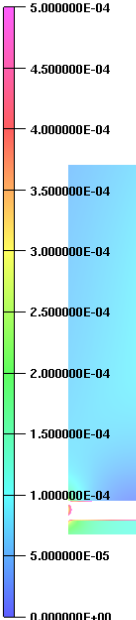

Integral = 2.743122E+07

MODEL 93 – 5 gauss scale

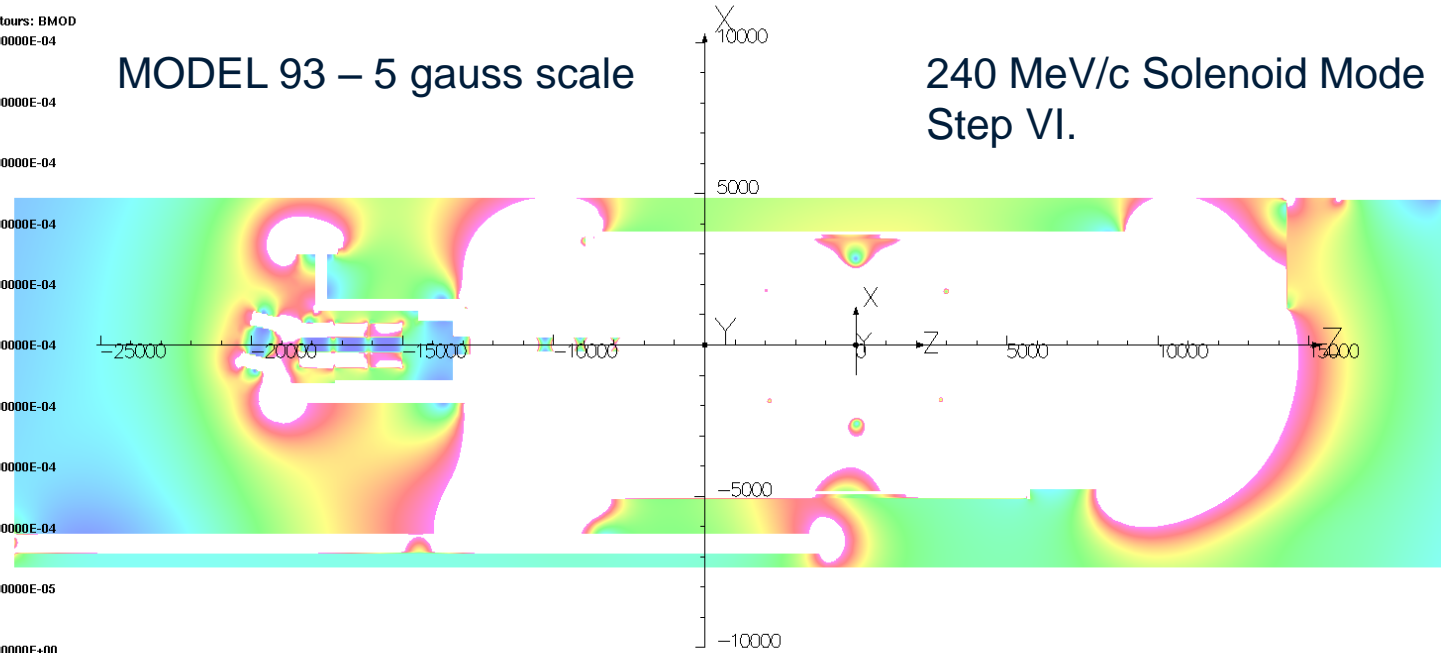

240 MeV/c Solenoid Mode Step VI.

For Comparison: MODEL 96 – 5 gauss scale

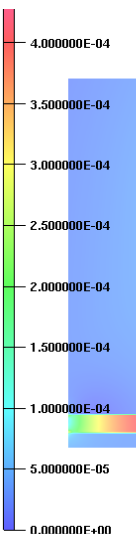

Integral = 3.110028E+07

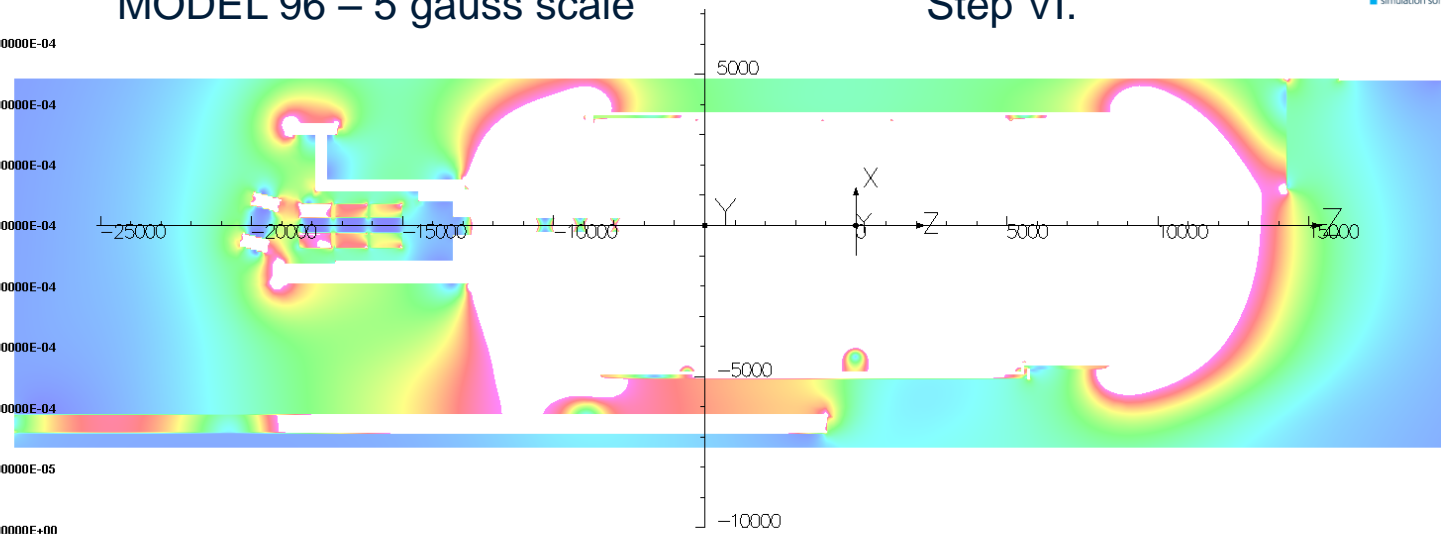

240 MeV/c Flip Mode Step VI.



UNITS

Length	mm
Magn Flux Density	T
Magnetic Field	A/m
Magn Scalar Pot	A
Current Density	A/mm ²
Power	W
Force	N

MODEL DATA

Hall_Test_93.op3
Magnetostatic (TOSCA)
Nonlinear materials
Simulation No 1 of 1
17433895 elements
29656623 nodes
18 conductors
Nodally interpolated fields
with coil fields by integration
Activated in global coordinates

Field Point Local Coordinates

Local = Global

FIELD EVALUATIONS

Cartesian	CARTESIAN	952x244	Cartesian
	(nodal/inte)		
	x=-7343.0 to	y=0.0	z=-27858.0 to
	4851.0		19736.0

MODEL DATA

Hall_Test_96.op3
Magnetostatic (TOSCA)
Nonlinear materials
Simulation No 1 of 1
17442133 elements
29677212 nodes
18 conductors
Nodally interpolated fields
with coil fields by integration
Activated in global coordinates

Field Point Local Coordinates

Local = Global

FIELD EVALUATIONS

Cartesian	CARTESIAN	952x244	Cartesian
	(nodal/inte)		
	x=-7343.0 to	y=0.0	z=-27858.0 to
	4851.0		19736.0



Conclusions



- We have successfully developed a tool that allows us to predict the stray field produced from the MICE magnets in the MICE hall and the surrounding buildings. The results from these models have been made publicly available as well as an extensive image library.
- A lot of work has been put into developing the model to ensure within the limitation of producing a tractable model that it accurately represents the stray field within the MICE hall.
- The model has been instrumental in isolating likely problem areas and making initial predictions of the stray field in many areas both within and surrounding the MICE Hall.
- The complexity of the model has prevented us from benchmarking the model, and herein lies the greatest risk and reason for not recommending the model to be used as the basis for the baseline solution.
- Although not shown in this presentation the the early yoke design for Step IV has been implemented in the model and so can be continued to be used to support the field prediction effort.