

| Item Number | Document Number | Title | Quantity |
|-------------|-----------------|----------------------|----------|
| 1 | TD-1152-9148 | AFC 18-7-11 | 1 |
| 2 | TD-1189-1699 | SIMPLE YOKE ASSEMBLY | 1 |

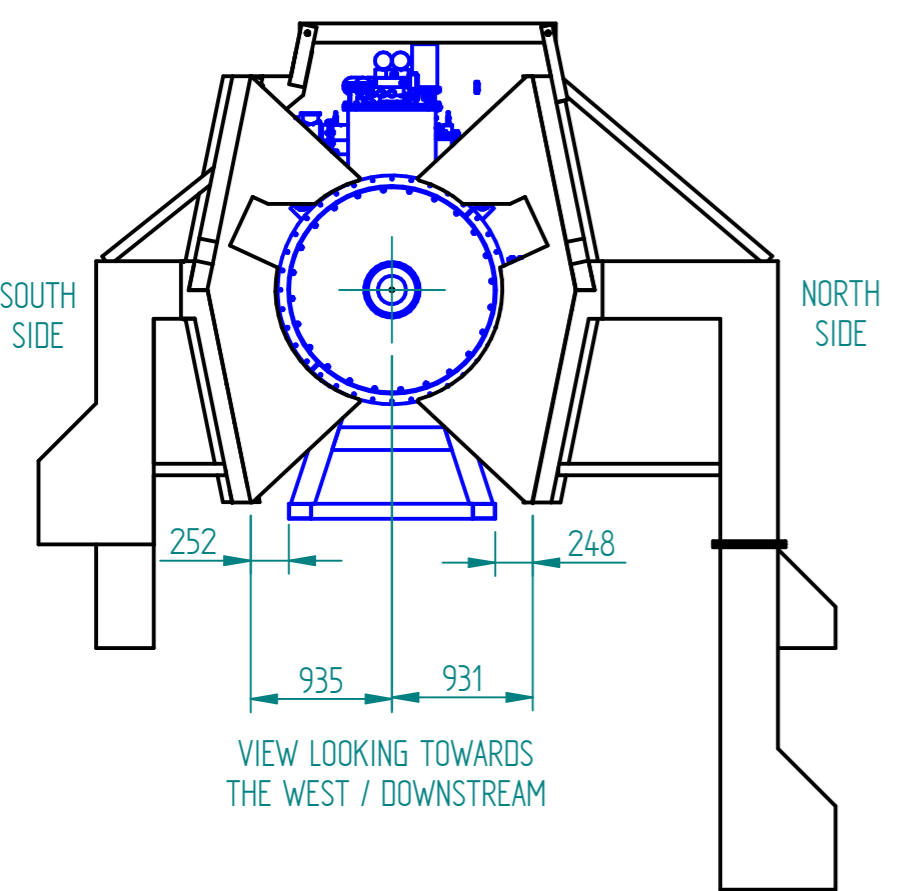
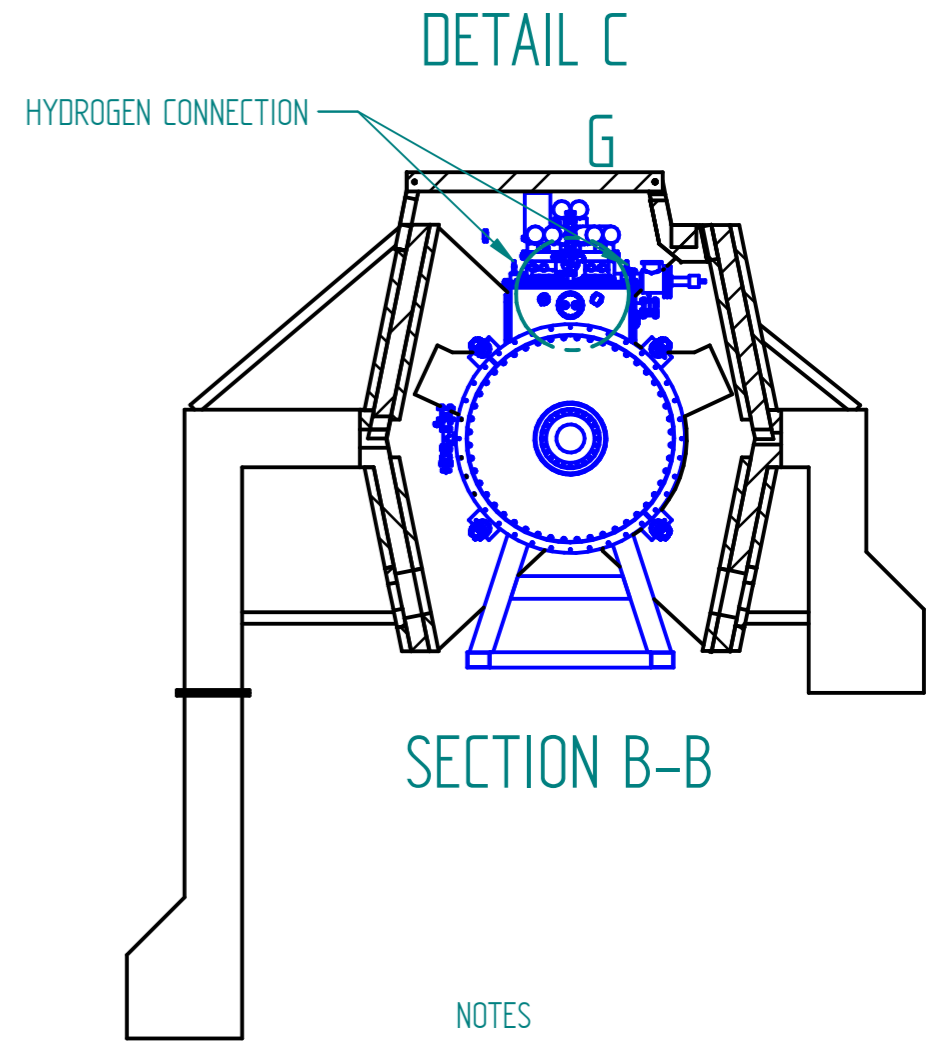
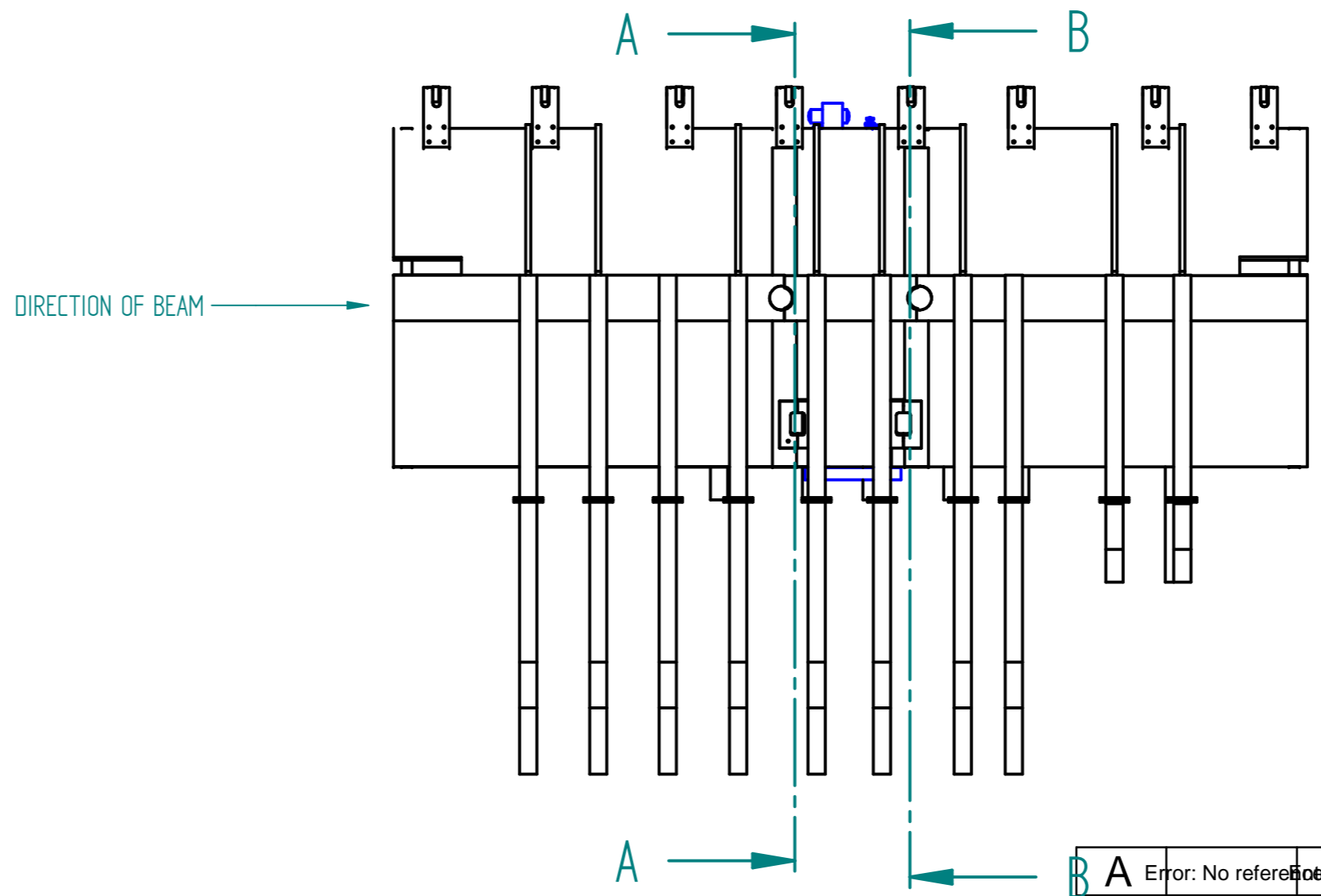
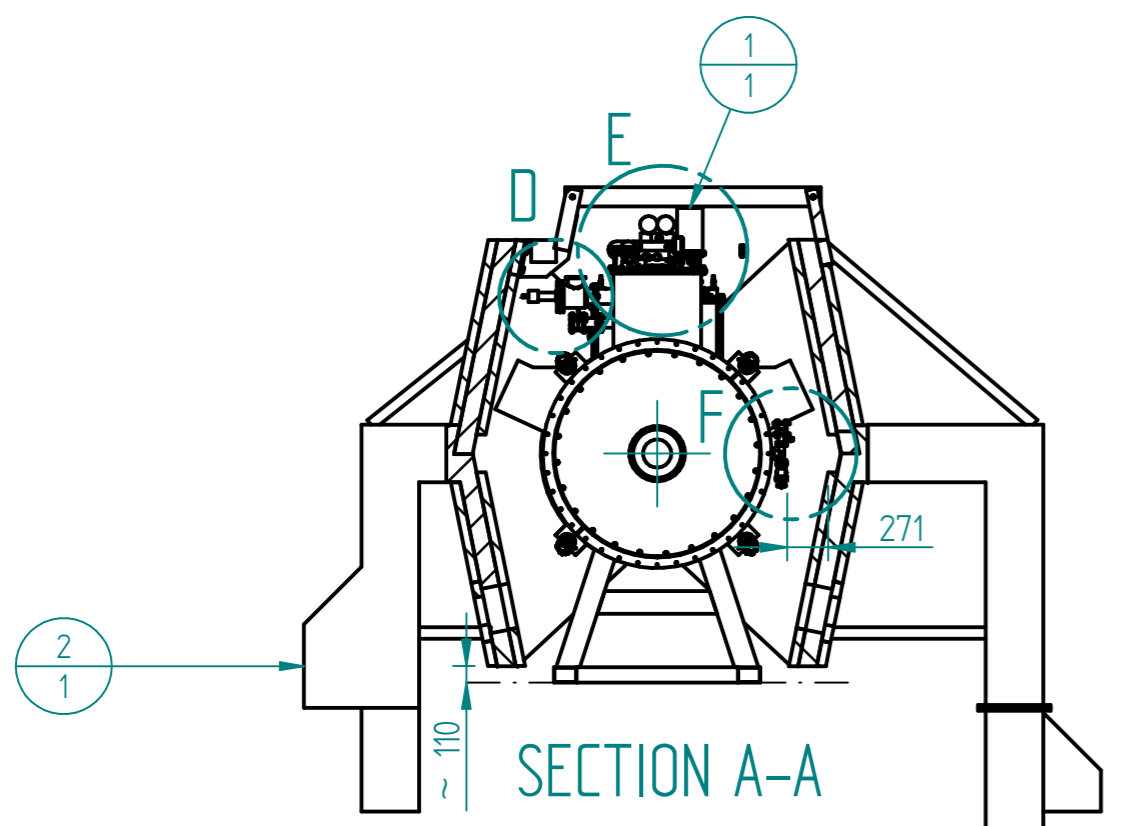
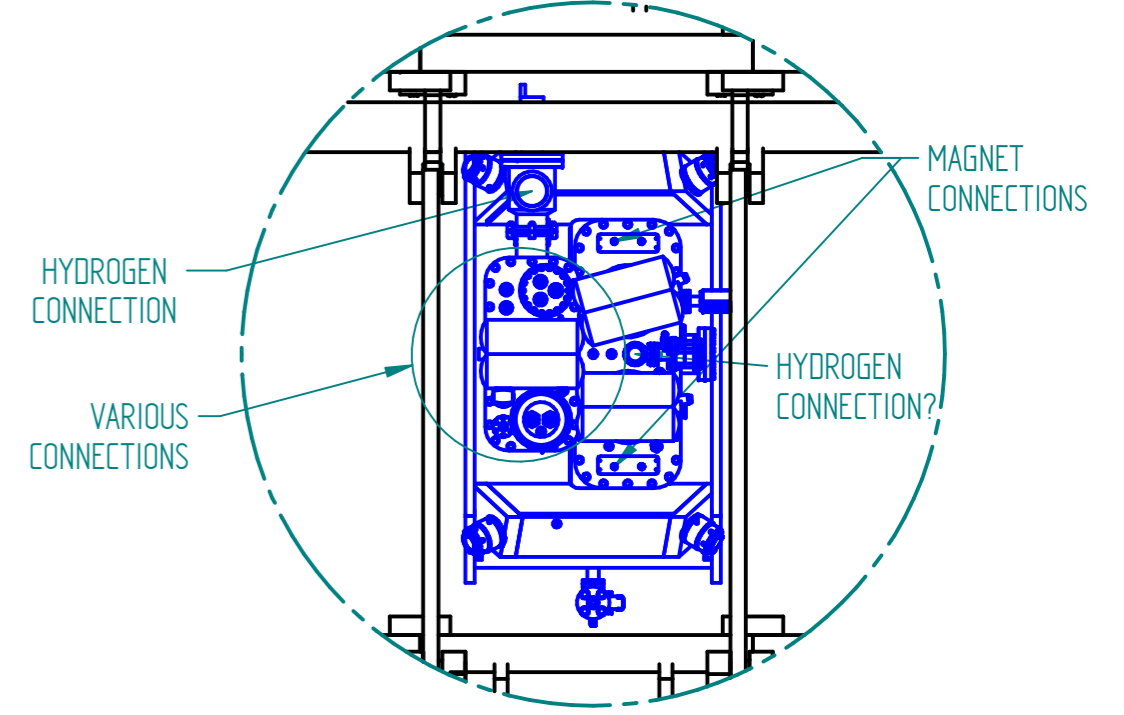
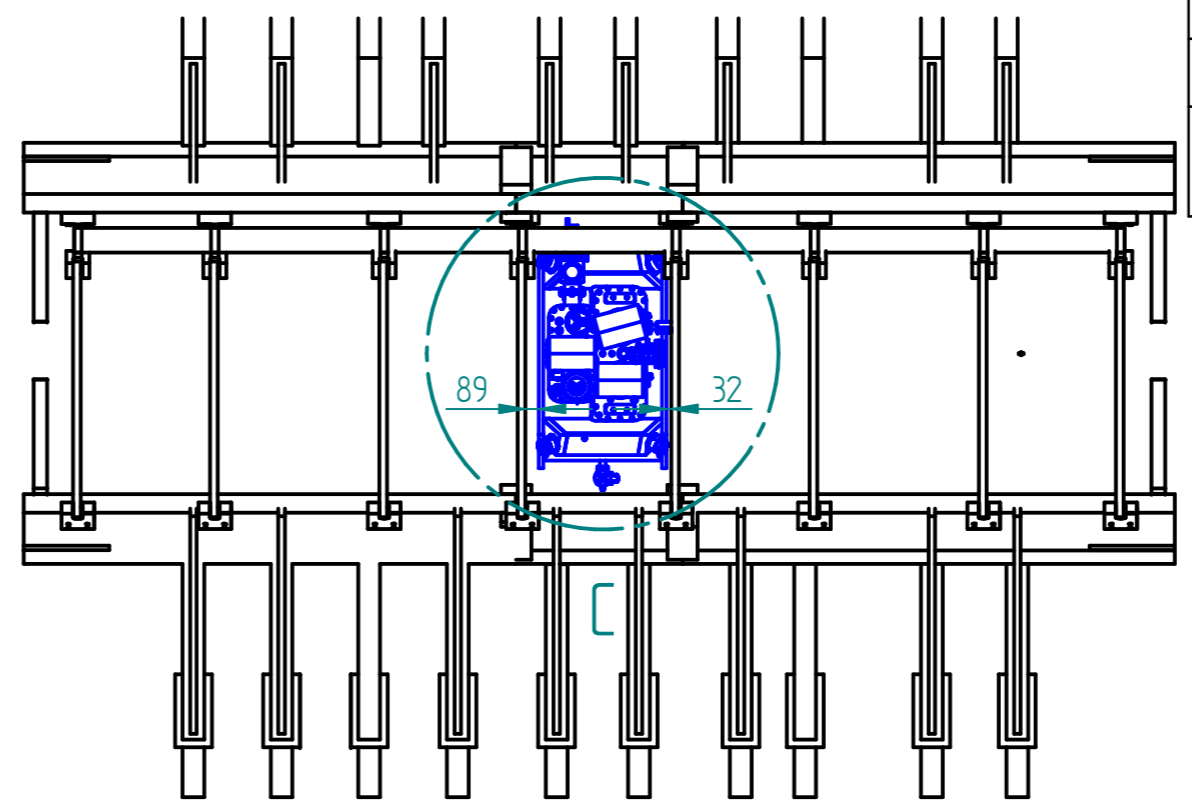
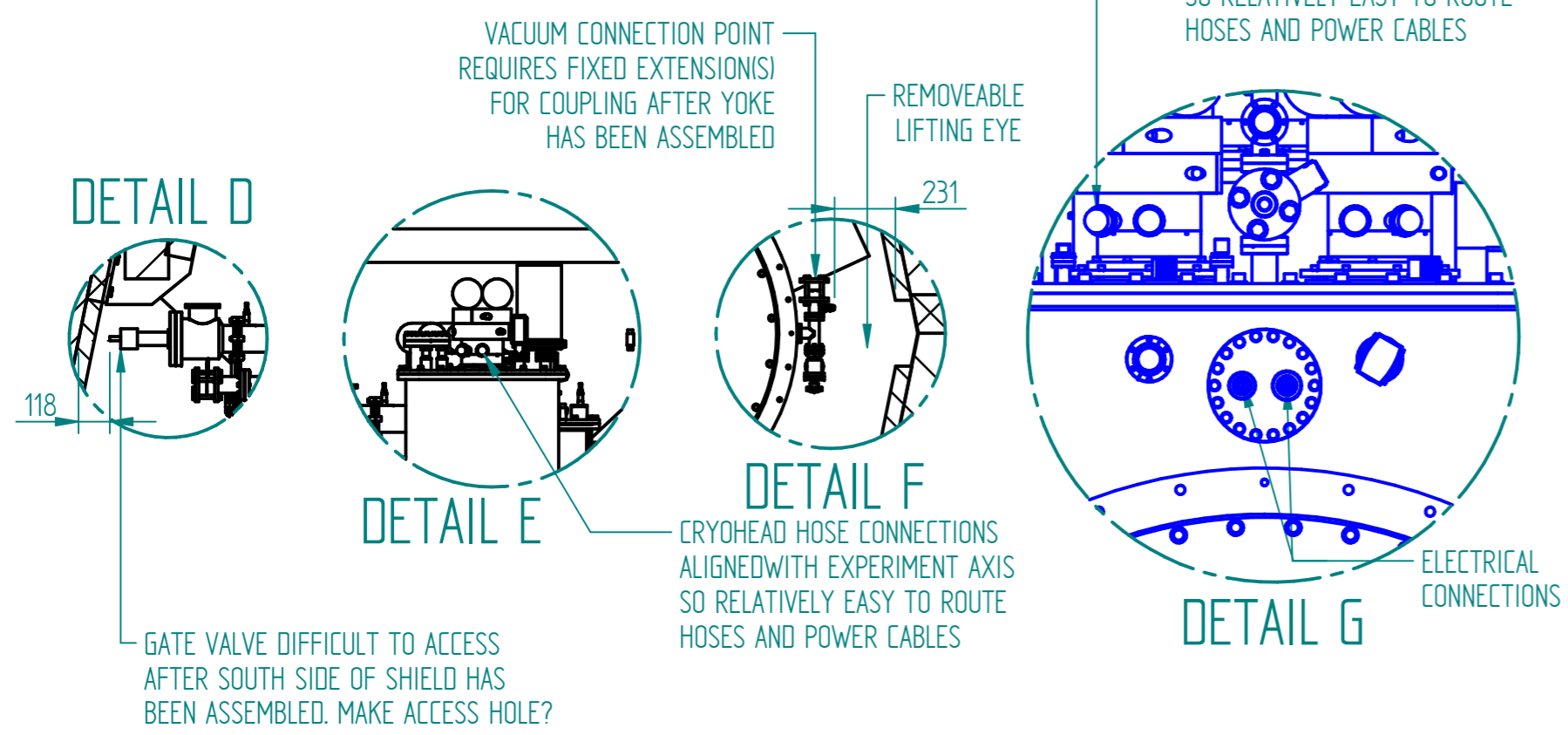

FOR REVIEW ONLY
DRAFT - 19/09/13

NOTES
1/ ALL DIMENSION AS MODELLED TO NEAREST mm

| | | | | | | | | | |
|--|--------------|--------------|------------------|---------------------|------------------------------|--------------------------|--------|--|---------------------|
| A Error: No reference | | Issue Mod No | J S TARRANT | Error: No reference | | Error: No reference | | MANUFACTURE ONLY WHEN STATUS IS RELEASED | Error: No reference |
| ISSUE | DATE APPD | MOD. No. | DRAWN BY | CHKD BY | APPD BY | TOLERANCES UNLESS STATED | | SURFACE TEXTURE | |
| | | | | | | LINEAR ± SEE NOTE 1 | | N/A | |
| | | | | | | ANGULAR ± N/A | | μm | |
| DRAWING CONFORMS TO BS 8888 TOLERANCING ISO 8015 | | | MATERIAL & SPEC. | | MASS 0.000 kg | FINISH | | | |
| DIMENSIONS IN mm UNLESS STATED | | | | | | N/A | | | |
| PROJECTS & MECHANICAL ENGINEERING GROUP (RAL) | | | | | USED ON MAGNETIC YOKE CHECKS | | | | |
| HARWELL SCIENCE & INNOVATION CAMPUS, RUTHERFORD APPLETON LABORATORY, CHILTON, OXON, OX11 0QX | | | | | | | | | |
| AFC WITH YOKE | | | | | | | | | |
| MAGNETIC SHIELDING YOKE | | | | | | | | | |
| MICE TDR126 | | | | | | | | | |
| A2 | TD-1189-1667 | | | | SHEET | | 1 of 1 | | A |