

Item Number	Document Number	Title	Quantity
1*	TD-1152-9013	MICE-ISIS COORD-SYSTEMS	1
2	TD-1189-4001	STEP IV C.CHANNEL ENVELOPE	1
4	TD-1152-9330	MAUS QUADRUPOLE Q35-7_8_9	1
5	TD-1189-1016	SHIELD WALL ENV	1
7	TD-1189-1387	HYDROGEN FILL ASSY (-2013)	1
8	TD-1189-1388	HYDROGEN FILL ASSY (2013+)	1
9	TD-1189-1462	TRACKER CRYO MOVE	1
12	TD-1189-1025	SIMPLE N-MEZZ EXTENSION	1
13*	TD-1189-1464	TRACKER CRYO STEP IV (SIMPLE)	1
14	TD-1152-9043	TRACKER PATCH PANEL (SOLID)	2
15	TD-1189-1746	SOUTH MEZZ YOKE CHANGE	1
16	TD-1189-1699	SIMPLE YOKE ASSEMBLY	1
17	TD-1189-1740	STEP IV MOVEABLE FLOORING ASSY	1

**FOR REVIEW ONLY
DRAFT - 19/09/2013**

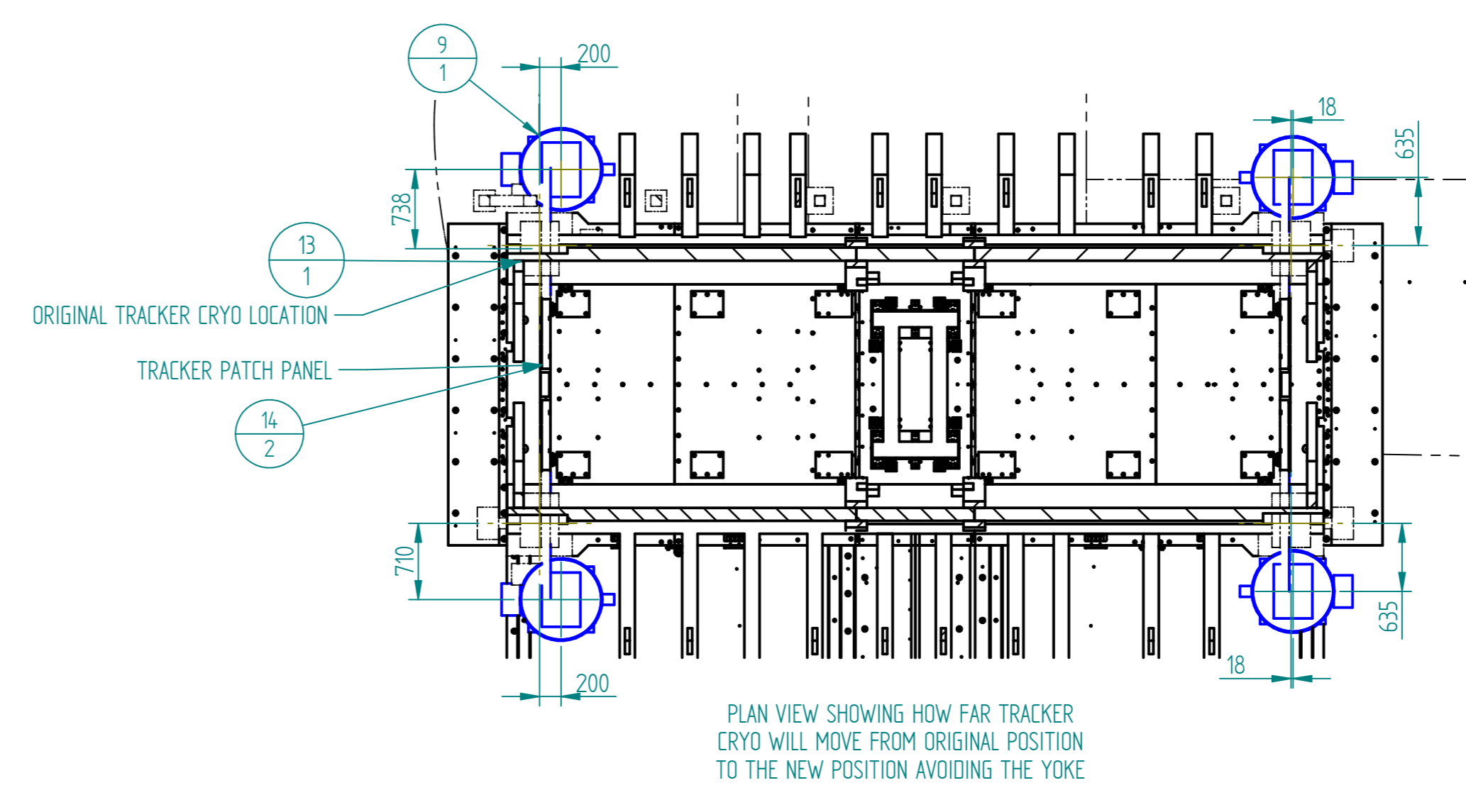
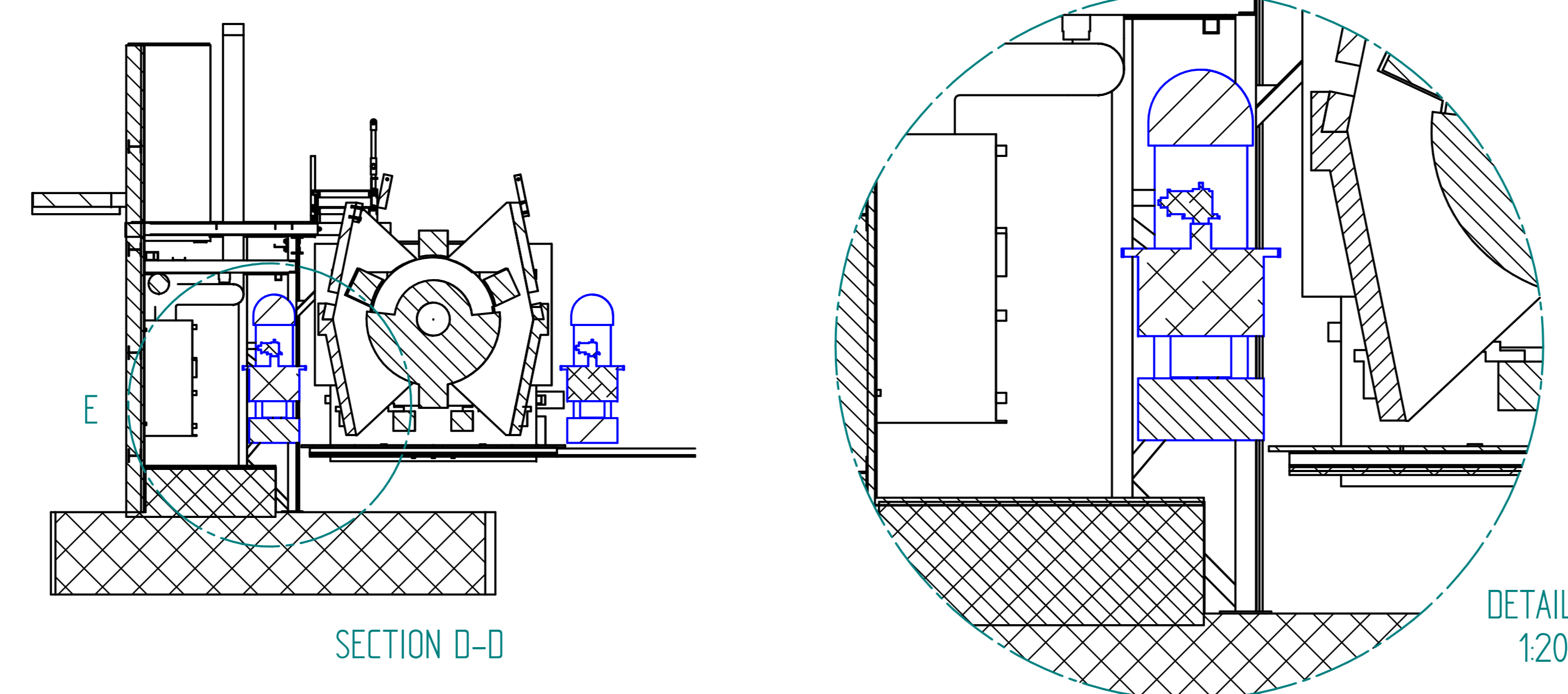
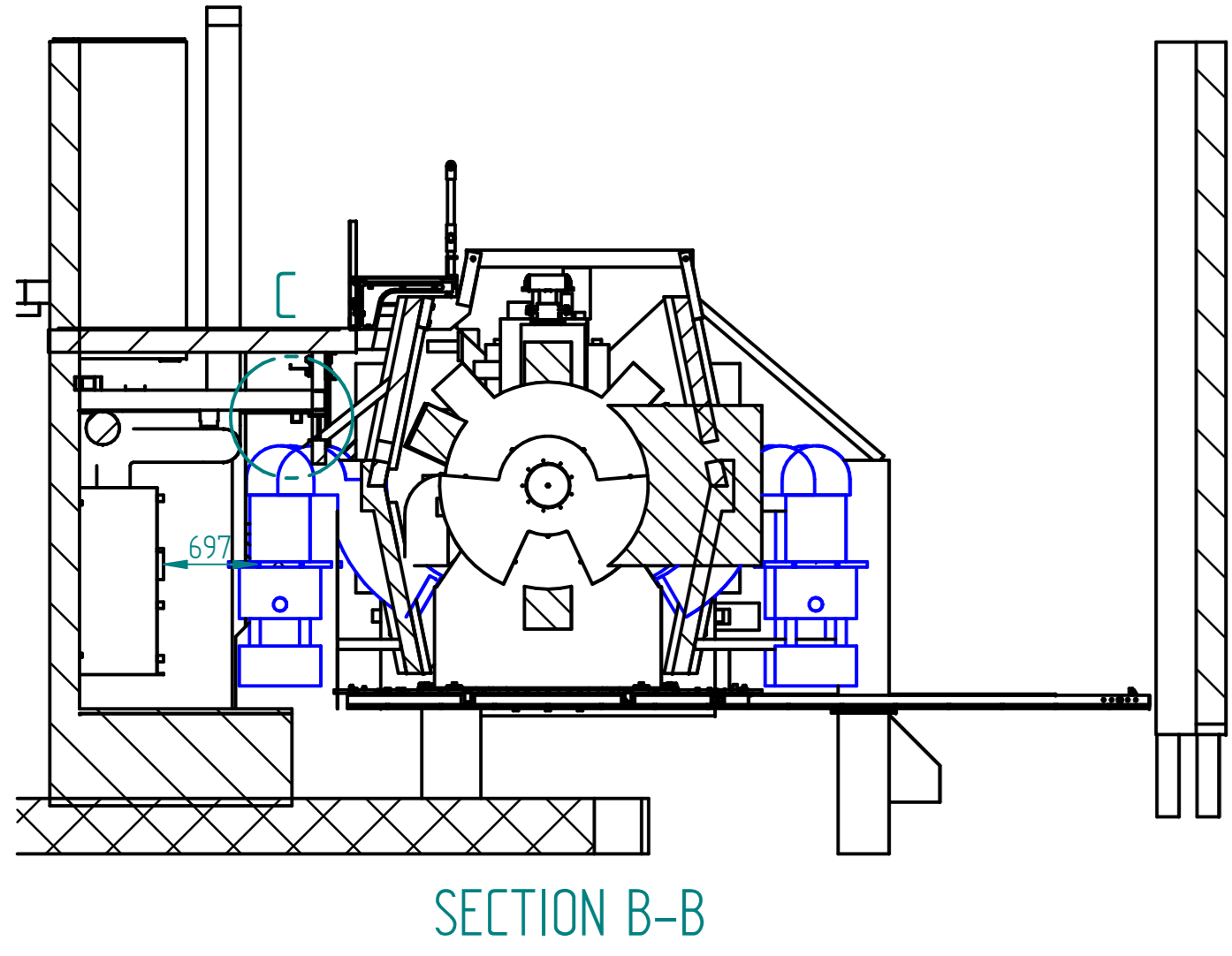
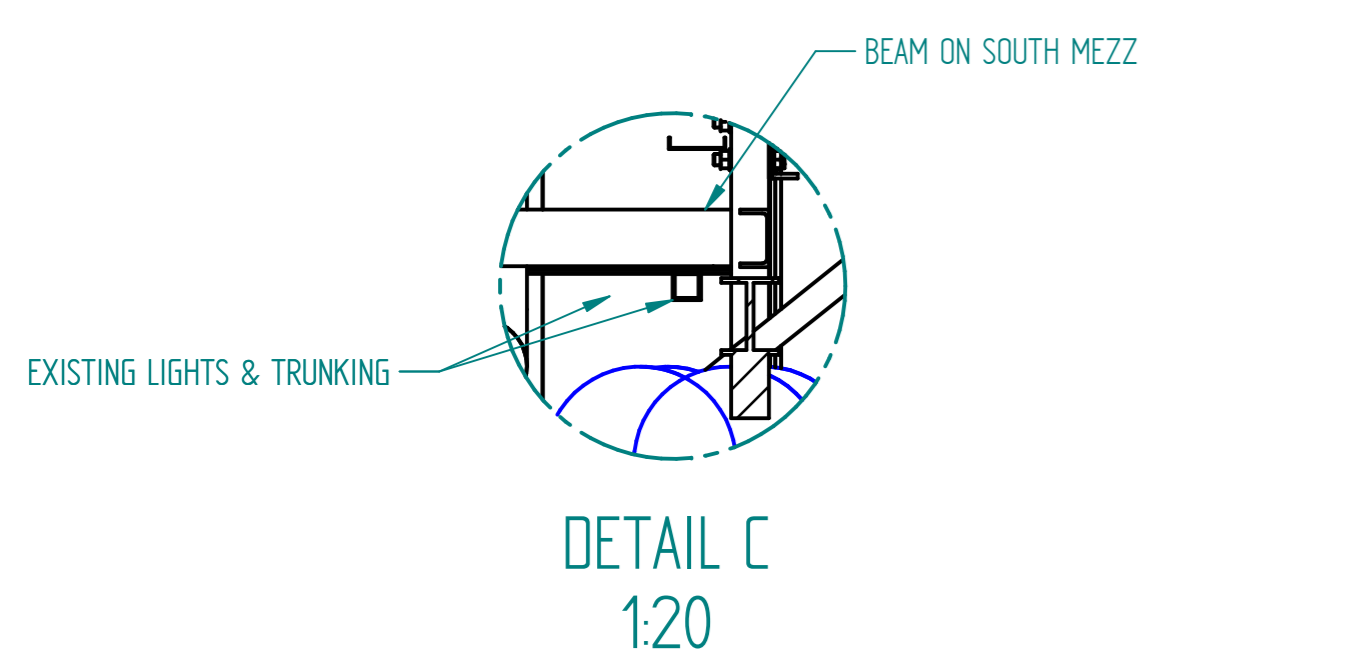
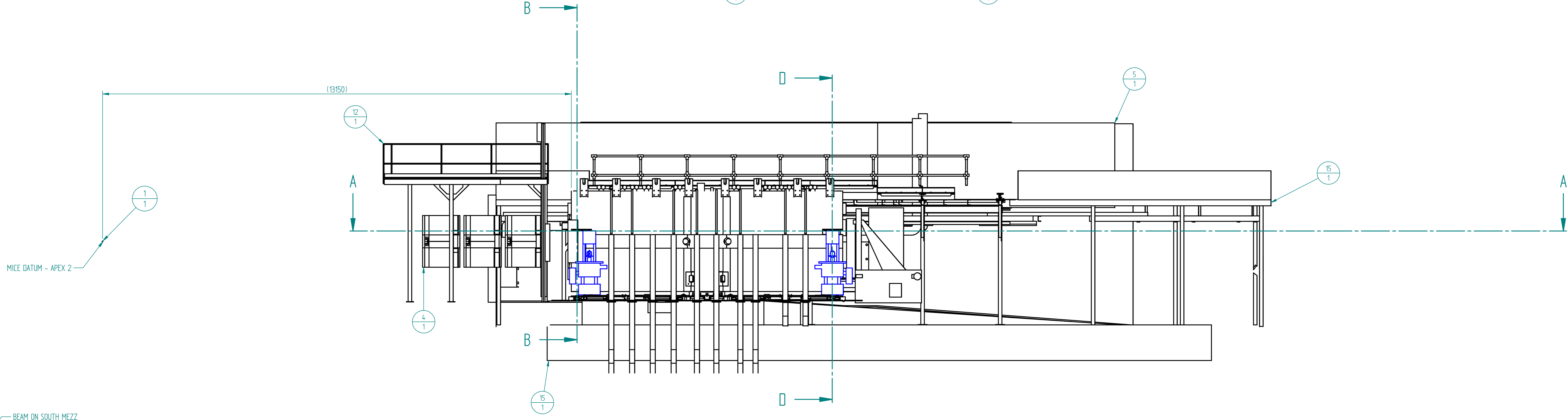
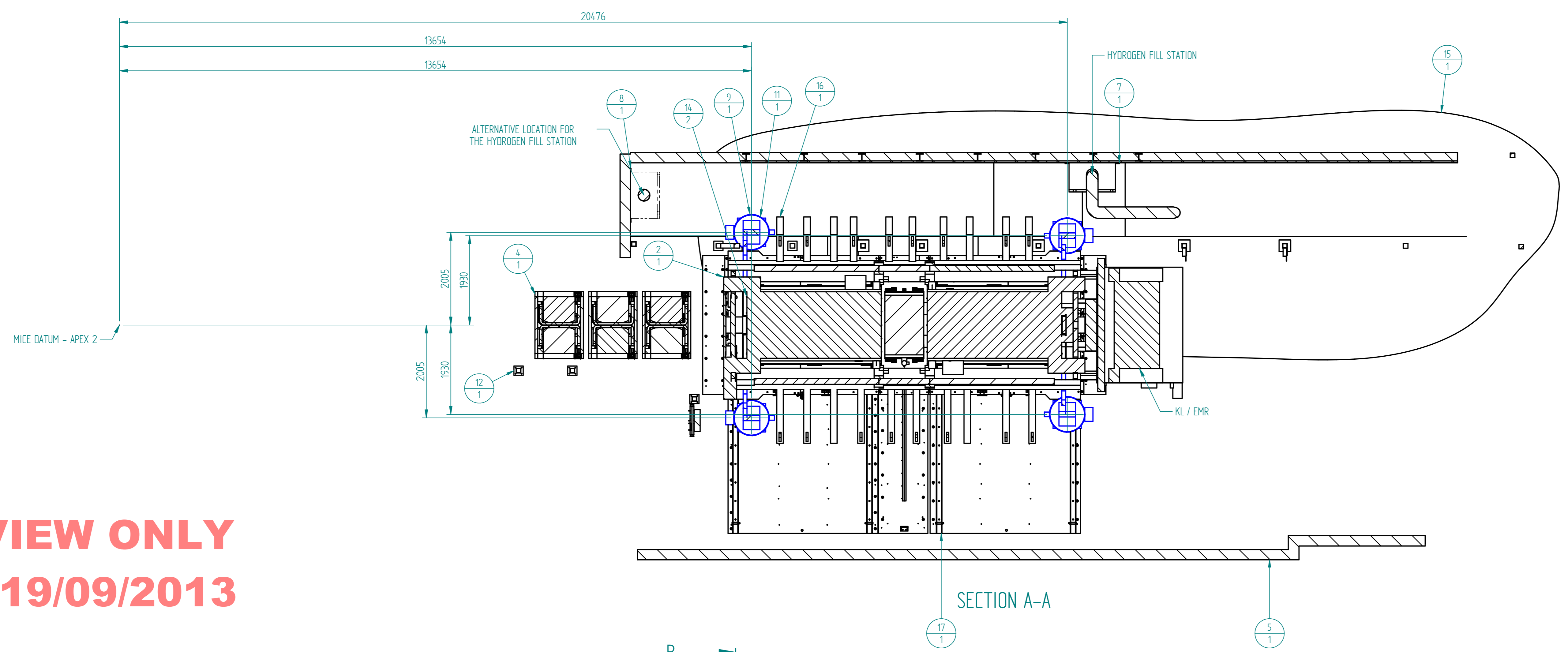

A Error: No reference		J S TARRANT Error: No reference		MANUFACTURE Error: No reference	
ISSUE	DATE APPD	MOD. No.	DRAWN BY	CHKD BY	APPD BY
TOLERANCES UNLESS STATED			SURFACE TEXTURE		
LINEAR ± 0.1			N/A μm		
ANGULAR ± 1			N/A		
MATERIAL & SPEC. MASS 0.000 kg			FINISH		
REMOVE ALL BURRS			REMOVE ALL BURRS		
DIMENSIONS IN mm UNLESS STATED			USED ON MAGNETIC YOKE CHECKS		
PROJECTS & MECHANICAL ENGINEERING GROUP (RAL)			HARWELL SCIENCE & INNOVATION CAMPUS, RUTHERFORD APPLETON LABORATORY, CHILTON, OXON, OX11 0QX		
TRACKER CRYO WITH YOKE MICE INTEGRATION ENGINEERING					
A0 TD-1189-1461		SHEET		1 of 1	